

CPWR TECHNICAL REPORT

The Effects of Debris Accumulation Upon Air Flow and Filter Resistance to Air Flow for Four Commercially Available Vacuum Cleaners

May 2008

**William A. Heitbrink Ph.D., CIH
and
Javier Santalla Elias**

William A. Heitbrink Ph. D. CIH
Associate Professor

Javier Santalla Elias
Graduate Research Assistant

May 1, 2008

Prepared for
Center to Protect Workers Rights

Department of Occupational and Environmental Health
College of Public Health
The University of Iowa
Iowa City Iowa 52241

CONTENTS

ABSTRACT	4
INTRODUCTION	5
OBJECTIVE	9
MATERIALS AND METHODS	9
Vacuum cleaners	9
Experimental Equipment	12
Experimental Procedures	13
Vacuum Cleaner Flow Loss, Changes in Filter Pressure Losses, and Accumulated Debris	14
Data analysis	15
RESULTS AND FINDINGS	16
DISCUSSION	22
CONCLUSION	23
BIBLIOGRAPHY	24

FIGURES

Figure 1. A vacuum cleaner exhausts air from a hood mounted on a grinder used for mortar removal.....	5
Figure 2. Exhaust airflow through Dust Director vacuum cleaner operated with 12 feet or 1.5 inch diameter corrugated hose.	8
Figure 3. Schematic diagram of the four vacuum cleaners listed in Table 3.	10
Figure 4. Apparatus for obtaining vacuum cleaner fan curve.	13
Figure 5. Apparatus for measuring pressures and flows before and after loading vacuum cleaner with mortar debris.	14
Figure 6. Airflow as a function of cumulative mass of debris sucked into the vacuum cleaner.	19
Figure 7. Flow rate resistance for pre-filters into Bosch (8A) and Dust Director (8B and 8C) vacuum cleaners.	20
Figure 8. Filter pressure loss/airflow for each vacuum cleaner.	21

TABLES

Table 1. Summary statistics describing flow rate and flow rate loss during mortar removal.....	8
Table 2. Vacuum cleaners selected for study.....	11
Table 3. Summary statistics describing flow rate and flow rate loss during mortar removal.....	17
Table 4. Probability that chance explained the fit of the regression line to the data.....	18

ABSTRACT

In order to adequately control dust exposures during mortar removal, vacuum cleaners need to exhaust 80 cfm from an exhaust hood on the grinder and maintain this air flow while collecting as much as 35 pounds of debris in the vacuum cleaner. A laboratory study was conducted to evaluate how mortar debris affects air flow and pressure losses through a vacuum cleaner's filters. Four vacuum cleaners were tested. Two of the vacuum cleaners used vacuum cleaner bags as a prefilter while the other two vacuum cleaners used cyclones to reduce the amount of debris which hits the filter. To conduct the testing, a contractor provided mortar removal debris that had been collected during actual mortar using grinder hood and a vacuum cleaner which involved cyclonic pre-separation. The vacuum cleaner fan curves were obtained experimentally to learn how pressure loss affects vacuum cleaner air flows. Then, 35 pounds of mortar removal debris was sucked into the vacuum cleaner in 5 pound increments. Before and after adding each five pound increment of debris, vacuum cleaner air flows were measured with a venturi meter and vacuum cleaner static pressures were measured at the inlet to the vacuum cleaner motor, before each filter and after each filter. The vacuum cleaners equipped with cyclonic pre-separation were unaffected by the mass of debris collected in the vacuum cleaner. These vacuum cleaners were able to maintain air flows in excess of 70 cfm throughout the testing program. As debris accumulated in the vacuum cleaners that used vacuum cleaner bags, air flow decreased from 80 cfm to as little as 30 cfm. This air flow loss is caused by the increased air flow resistance of the vacuum cleaner bags which increased from less than 0.1 inches of water per cfm to 2 inches of water/cfm which is 60 inches of water at an airflow of 30 cfm. Apparently, vacuum cleaners using vacuum cleaner bags should be used in applications where adequate dust control can be achieved at air flows less than 30 cfm. Where higher air flows are needed, vacuum cleaners should incorporate cyclonic pre-separation in an effort to prevent debris from reaching the vacuum cleaner final filters.

INTRODUCTION

During construction and renovation tasks, the cutting and grinding of concrete and masonry material can cause excessive exposure to respirable crystalline silica.¹ More than 35,000 non-residential construction workers in the United States are exposed to more than twice the National Institute for Occupational Safety and Health (NIOSH) Recommended Exposure Limit (REL) for crystalline silica.^{2,3} This exposure limit is 0.05 mg/m³ for respirable crystalline silica.⁴ The use of right angle grinders to remove deteriorated mortar from buildings causes a particularly excessive exposure to respirable crystalline silica. During mortar removal, occupational exposures to respirable crystalline silica are reportedly as high as 5 mg/m³.

Other construction and renovation tasks such as concrete grinding, concrete drilling, brick cutting, cutting roofing tile are also reported to cause excessive exposure to crystalline silica.¹ The ACGIH TLV for respirable crystalline silica is an 8-hour time weighted average of 0.025 mg/m³ of respirable crystalline silica is intended to prevent pulmonary fibrosis (silicosis) and lung cancer.^{5,6} In summarizing the findings from the literature, ACGIH noted that, “when retirees whose workplace silica-exposure concentrations averaged 0.06 mg/m³ were studied, the risk of silicosis was significantly greater (7.1% versus 1.2%) when compared to employees examined at or before retirement.”⁷ Thus, ACGIH recommends that worker exposures should be kept below 0.025 mg/m³ so that workers will not have silicosis at retirement.⁶ Thus, effective control measures are needed to reduce worker exposure to crystalline silica.

To remove deteriorated mortar, workers use hand-held, right angle grinders equipped with a 4.5 inch (11 cm) grinding wheel rotating at 10,000-12,000 rotations per minute (rpm) to pulverize the deteriorated mortar which contains crystalline silica. While operating the right angle grinder, the worker applies pressure to the grinding wheel to maintain a cut depth of 0.39-0.79 inch (1-2 cm). To capture the dust, a vacuum cleaner can be used to exhaust a minimum of 80 cubic feet per minute (cfm) (2.26 m³/min) from a hood that is mounted on the grinder as shown in Figure 1.⁸ When airflows fall below 76 ft³/min in a 2 inch hose, the air velocity in the hose will be less than the 3500 ft/min (fpm) specified to prevent debris from accumulating in ventilated ducts and plugging them.⁹ This finding was based upon laboratory and computational studies. During field trials, respirable crystalline silica exposures for 22 samples had a geometric mean of 0.06



Figure 1. A vacuum cleaner exhausts air from a hood mounted on a grinder used for mortar removal.

mg/m³ and a range of less than 0.01 to 0.86 mg/m³.¹⁰ In other studies, geometric mean respirable crystalline silica exposures during mortar removal were reported to be between 0.35 and 1.1 mg/m³.^{1, 8, 11} The use of local exhaust ventilation (LEV) during tuck point grinding dramatically decreases personal dust exposure levels about 5-20 times less than tuck point grinding conducted without any engineering control.¹⁰ Therefore, grinders with LEV should be used in order to control exposure to respirable crystalline silica.

During field trials, vacuum cleaners flow rates decreased as debris accumulated in the vacuum cleaner.¹⁰ The vacuum cleaner air flows showed a periodic fluctuation (Figure 2) as vacuum cleaner filters were treated to dislodge debris that had caked onto filters.¹⁰ As summarized in Table 1, actual cleaner air flow rates had an average initial flow rate between 104 and 70 cfm. However, the average flow rate decrease was between 3 to 0.4 cfm/minute over a range of vacuum cleaners and hose diameters.¹⁰ At a flow rate loss of 3 cfm/min, vacuum cleaner air flows can be negligible after a period of only 30 minutes.

In Table 1, a vacuum cleaner used with a cyclone, the DustControl 2700, had a more stable airflow than the other vacuum cleaners. Cyclones are sometimes used as preseparators that collect debris upstream of filters. In a cyclone, larger size particles are separated from the air stream by impaction on the cyclone's wall. This cyclonic preseparator for The DustControl vacuum cleaner has a pressure loss of 6 inches of water at 85 ft³/min which reduces the initial airflow by about 9 ft³/min.^{10,12} However, the cyclones may reduce the amount of debris that accumulates on the vacuum cleaners' filter in order to maintain adequate airflow.

Vacuum cleaner air flows were obtained by measuring vacuum cleaner static pressure, the pressure in the space between the final filter and the inlet to the vacuum cleaner motor.¹⁰ An experimentally determined fan was used to convert vacuum cleaner static pressure to air flow. Vacuum cleaner fan curves, relation between vacuum cleaner static pressure and air flow, are stated mathematically as:¹²

$$Q = m (\Delta P_{v-sp}) + b \quad (1)$$

Where;

Q = the air flow (cfm),

ΔP_{v-sp} = the static pressure at the vacuum cleaner motor inlet (inches of water), and

m, b = regression coefficients for, respectively, the slope and intercept.

The R² values, the fraction of the variability explained by the vacuum cleaners' fan curve, was better than 0.98.¹⁰ The intercept (b) is the air flow with no pressure loss and this airflow is sometimes called "the free air flow". The slope (m) is always less than zero as flow rate decreases with increasing static pressure. The slope has these dimensions: cfm/inch of water. The flow rate loss attributed to the debris accumulation on the filters is the product of the slope multiplied by the increased pressure loss due to accumulation of debris on the vacuum cleaners' filters.

Increased filter pressure losses probably explain the loss of air flow that occurs with increased debris accumulation. Generally, air flow through a filter is proportional to the pressure loss across a filter. This proportionality constant should be independent of air velocity or air flow.^{12,13,}

¹⁴ For each filtration element, this proportionality constant (K_{filter}) is stated as:

$$K_{\text{filter}} = \Delta P_{\text{filter}} / Q \quad (2)$$

Where; ΔP_{filter} = pressure loss across a filter ; and

Q = vacuum cleaner air flow.

This model assumes laminar flow through the filters. As presented latter, the filter area for the final filters in the vacuum cleaner were between 0.4 and 2.1 m². At 80 cfm, the filter face velocities are between 18 and 0.8 fpm. Such low velocities are consistent with laminar flow. In this work, this proportionality constant (K_{filter}) is termed “filter resistance.” As vacuum cleaners accumulate debris, air flow rates decreases (Table 1). The filter resistance is means to normalize data for decreases in flow rate caused by increased filter loading.

Table 1. Summary statistics describing flow rate and flow rate loss during mortar removal					
Vacuum Cleaner	Hose Diameter (inches)	Average initial flow (cfm)	Geometric standard deviation	Average Flow rate loss (CFM/minute of grinding)	Geometric Standard Deviation
Shop Vac QUL650	2	104.79	1.21	3	1.81
Dust Director 9.5	1.5	84.78	1.11	2.01	1.47
Bosch 3931	2	79.28	1.08	1.17	1.72
Dust Director 9.5	2	88.68	1.21	1.16	1.48
Alto Wap SQ23	2	128.95	1.2	0.97	2.32
DustControl 2700	1.5	70.95	1.23	0.66	1.27
DustControl 2700 (with/ cyclonic pre-separator)	2	90.21	1.04	0.41	1.39

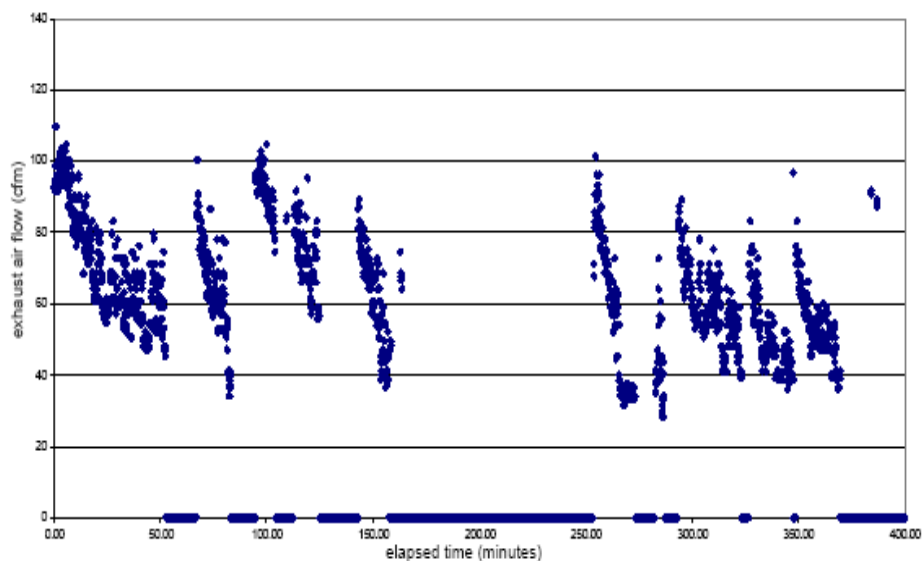

Figure 2. Exhaust airflow through Dust Director vacuum cleaner operated with 12 feet or 1.5 inch diameter corrugated hose.

OBJECTIVE

Clearly, the amount of debris accumulating in vacuum cleaners reduces the air flow needed to control the dangerous exposures caused by mortar removal. This reduced air flow can potentially increase the emissions of respirable crystalline silica into the worker's breathing zone. Thus this research was conducted to evaluate how debris accumulation within the vacuum cleaner affects vacuum cleaner flow rate and pressure loss through the vacuum cleaner filters. The flow rate loss due to debris accumulation is simply the product of the pressure loss across a filter (ΔP_f) and the slope of the vacuum cleaner fan curve (m).

MATERIALS AND METHODS

This testing was conducted to assess how the mass of material collected in four vacuum cleaners affects vacuum cleaner air flow and filter pressure losses. These vacuum cleaners have different characteristics that are listed in Table 2, and those characteristics influence the pressure loss across the various vacuum cleaner filters and the vacuum cleaner air flow.

Vacuum cleaners

The vacuum cleaners listed in Table 2 are all commercially available. All of these vacuum cleaners require less than 17 amperes and can be reasonably used on swing stages. These vacuum cleaners were selected because the design features differ. The range of filter area for the final filters is 0.4 to 2.1 m². Two of the vacuum cleaners use vacuum cleaner bags as prefilters. All of these vacuum cleaners are available with optional filters that are 99.97% efficient at 0.3 μm (HEPA filters). Experimentally, aerosol penetration through the Bosch and DustControl vacuum cleaners was under, respectively, 5% and 2% at 0.4 μm .¹⁵

The bodies of the Dust Control and Tiger-Vac vacuum cleaners have the shape of a cyclone with the final filter functioning as the vortex finder (Figure 3). This design is intended to separate the debris from the air upstream of the final filter. The settled debris is collected into a plastic bag or a pan. These vacuum cleaners were included in the study because the cyclones may remove airborne debris prior to filtration. Perhaps, this enhances flow rate maintenance.

A. Tiger Vac Vacuum cleaner

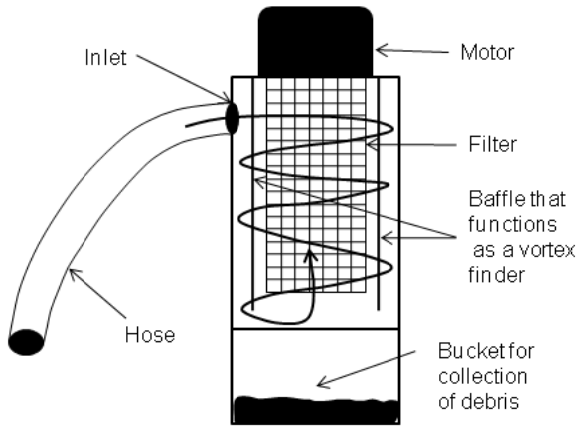

B. DustControl 2700 Vacuum cleaner

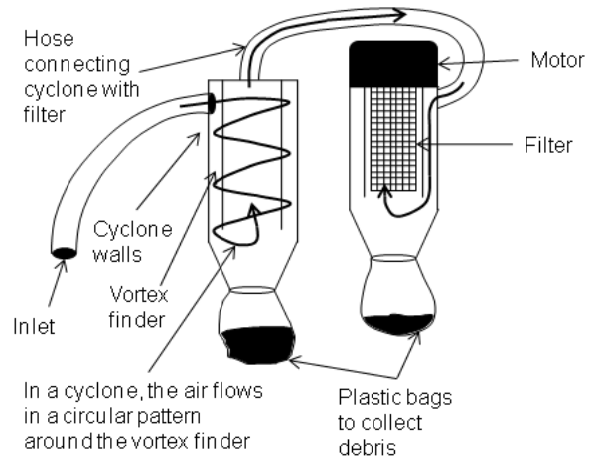

C. Bosch Vacuum cleaner

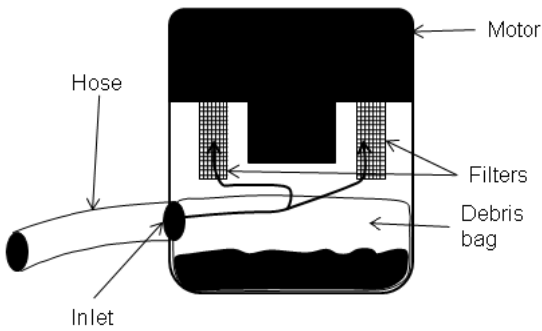

D. Dust Director Vacuum cleaner

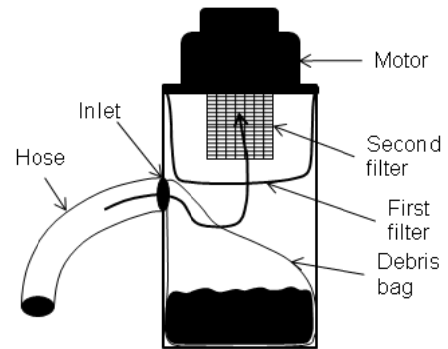

Figure 3. Schematic diagram of the four vacuum cleaners listed in Table 3.

Table 2. Vacuum cleaners selected for study				
Manufacturer	Model	Cost	Filtration	Description of filter cleaning for final filter
Bosch (Mt. Prospect Ill)	3931	\$400	Bag and Filter with a surface area of 0.86 m ² . The advertised filter efficiency is 99.93% of particles at 0.3 μm and larger.	Electric motor used to vibrate final filter when vacuum cleaner motor is off.
DustControl (Norsborg Sweden)	2700	\$1600	Filter and, sometimes used with cyclone. This vacuum cleaner has a tangential inlet. The filter area is 1.5 m ² . The advertised filtration efficiency is "better than 99.9%".	Cover inlet to vacuum cleaner and release vacuum removing plastic cover from a vent hole. This causes the final filter to flex and drop material into a plastic bag.
Industrial Contractor's Supply Dust Director (Pittsburgh Pa)	Contractor Plus Vacuum Cleaner	\$800	A paper vacuum cleaner bag and a final filter with an area of 0.4 m ² . Final filter efficiency is 99.97% at 0.3 μm. This manufacturer does not have model numbers.	Manually shake vacuum cleaner, turn vacuum cleaner on and off. This vacuum cleaner is not supposed to need cleaning.
Tiger-Vac (Laval Quebec CA)	2D-20DT	\$1500	This vacuum cleaner incorporates a cyclone as a prefilter and a 99.97% at 0.3 μm final filter. The final filter has an area of 2.11 m ² .	Manually pulse vacuum clean by blocking the vacuum cleaner inlet and opening the vacuum release flap. Turn motor on and off. The debris falls into a detachable pan.

Experimental Equipment

A venturi meter (Primary Flow Signal, Tulsa, OK) was used to measure vacuum cleaner airflows.¹⁶ This venturi meter has an inlet diameter of 2.067 inches and a throat diameter of 1.088 inches. Air flow is computed from the pressure difference between the inlet and the throat. The pressure differential was measured with a u-tube manometer and flow rate is computed as described in an ISO standard.¹⁷ The uncertainty with which the flow coefficient is known limits the accuracy of the flow rate measurement. For pipe Reynolds numbers larger than 75000, the uncertainty in the flow rate is under 1%. The ISO standard indicates that uncertainty is reduced from 2.5% to 1% as Reynolds number increases from 10,000 to 150,000. For flow rates obtained from this venture meter, the uncertainty in the flow rates is better than 1-2 cfm over a flow rate range of 12 to 230 cfm.

U-tube manometer (1211 Slack Tube® Manometer, Dwyer Instruments Inc. Michigan City, IN) was used to measure vacuum cleaner static pressures, pressure differentials across the venturi meter. The pressure range for this manometer is 120 inches of water and it is readable to the nearest 0.5 inches of water.

Pressure transducers (SmartReaderPlus4 -30A-part-01-0116, ACR Systems, Surrey, BC) were used to measure and record vacuum cleaner static pressures during testing. This pressure logger is a digital barometer that measures and records absolute pressure with 12-bit resolution over the range 0-30 pounds per square inch (psia). Thus, this instrument records pressure to the nearest 0.2 inches of water. The pressure transducers read pressures that were 4.90 inches of water less than a barometer (Nova Barometer, Princo, Southampton PA). Appendix E describes a regression equation for relating pressure transducers results to absolute pressures measured with a barometer and a u-tube manometer.

A shipping and receiving balance (Pelouze model 4010, W.W. Grainger Inc. Lake Forest, Ill) with 150 lb of capacity (68 kg) used to record the mass of material transferred to the vacuum cleaner. This balance weighs material to the nearest 0.2 pounds. In addition a balance (model SP602, Ohaus, Grainger Inc. Lake Forest, Ill) was used to weigh filters. This balance has a readability of 0.1 grams and it was used for weighing vacuum cleaner filters.

The mortar removal debris was supplied by Western Construction Group in August of 2008. It was obtained from a job site in the Midwest. This company uses hoods and vacuum cleaners to control the dust generated by mortar removal as described in prior publication.¹⁰ This debris was collected in the DustControl vacuum cleaners that were used without cyclonic pre-separators shown in Figure 3B.

Experimental Procedures

Prior to studying how debris accumulation affects vacuum cleaner flow rate and the pressure loss across the vacuum cleaners' filters, the relationship between vacuum cleaner air flow and static pressure at the inlet to the vacuum cleaner motor was determined using procedures that were developed earlier.¹⁰ The filters were removed from the vacuum cleaner and small holes were drilled into their body, flexible tubing was inserted into these holes. The holes were sealed with silicone caulk. The flexible tubing was used to measure vacuum cleaner static pressure and this tubing was connected to the pressure loggers or the a U-tube manometer.

The experimental apparatus shown in Figure 4 was used to determine the vacuum cleaner fan curve. The outlet of the venture meter was connected by 2-inch diameter, schedule 40 PVC pipe and flexible hose to the inlet of the vacuum cleaner. The vacuum cleaner air flow was obtained by measuring the pressure differential across a venturimeter (Primary Flow Signal) with a u-tube water manometer. Then, measured pressure differential was used to compute an air flow rate as described by an ISO standard.¹⁸ The pressure logger (SmartReaderPlus4 -30A-128kb memory – part-01-0116, ACR Systems, Surrey, BC) was used to measure vacuum cleaner static pressure during testing and this data was used to compare the static pressures measured with the pressure transducers to the static pressures measured with the venturi meter. The formula for computing vacuum cleaner static pressure (ΔP_{v_sp}) from the pressure transducer measurements is: $\Delta P_{v_sp} = P_{ambient} - P_{measured}$. The terms $P_{ambient}$ and $P_{measured}$ are, respectively, the absolute pressures measured by the pressure transducer when the vacuum

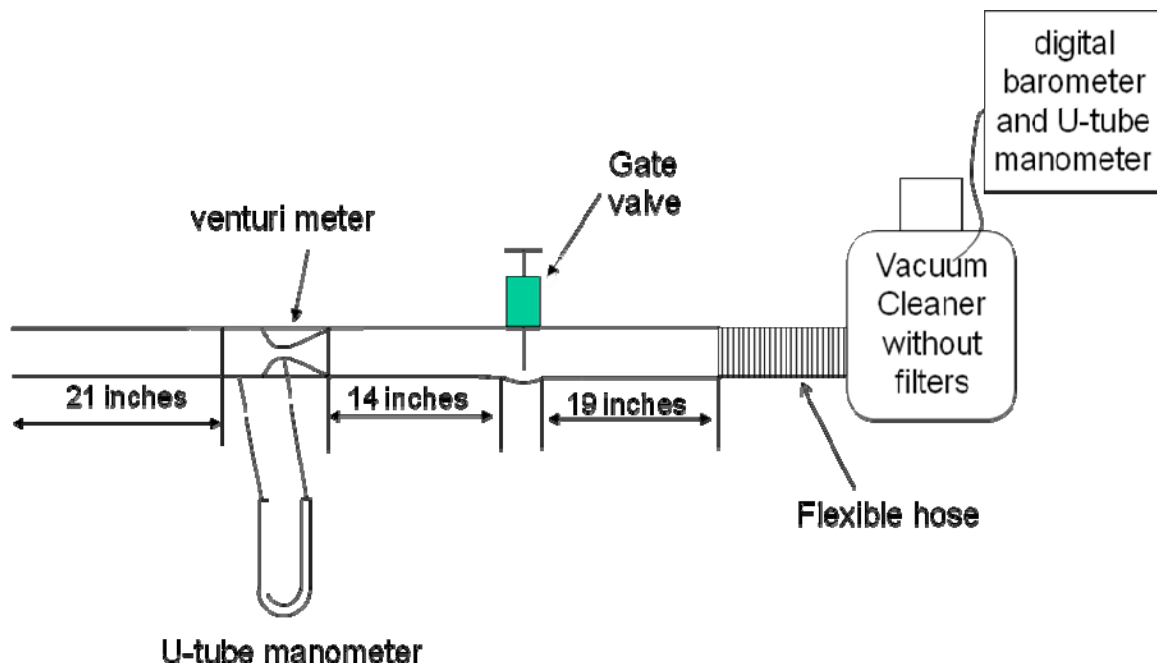

Figure 4. Apparatus for obtaining vacuum cleaner fan curve.

cleaner was off and when it was running.

A total of at least 10 equally spaced flow rates and vacuum cleaner static pressures were obtained by adjusting the gate valve shown in Figure 4 for each of the vacuum cleaners. Regression analysis (Regression tool that is a component of Microsoft Excel 2007, Microsoft, Redmond WA) was used to fit the data to this model described by equation 1. The regression analysis was used to compute the slope, intercept, the standard error of estimate, fraction of variability explained by the model, and the standard error for the intercept and slope.

Vacuum Cleaner Flow Loss, Changes in Filter Pressure Losses, and Accumulated Debris

The cumulative effect of material debris accumulation upon the pressure loss across vacuum cleaners' filters and air flow was determined. In increments of 5 pounds, 35 pounds of debris were sucked into vacuum cleaners. Before and after each five pound increment, vacuum cleaner air flows and pressure losses were measured as shown in Figure 5. The mortar debris used for the test was previously obtained from the Western Construction Group. As shown in

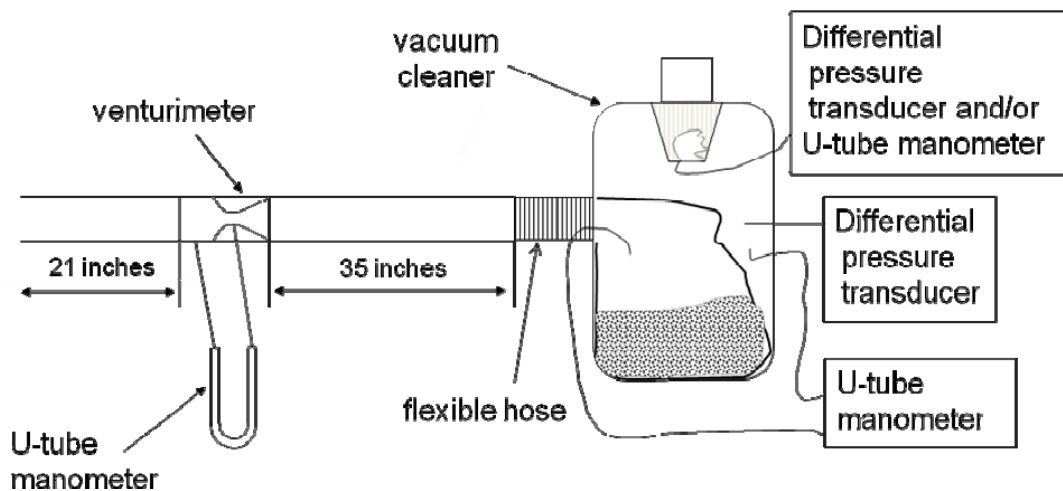

Figure 5. Apparatus for measuring pressures and flows before and after loading vacuum cleaner with mortar debris. When filter pressure losses were measured the venturi meter and pipe was disconnected from vacuum cleaner.

Figure 5, the pressure difference across the final filter and the initial air cleaner were measured with data logging pressure transducers (Smart Reader SRP-004-5G-128K 0-5 PSI-G, ACR Systems, Surrey BC, Canada) and with the U-tube manometer. These pressure transducers

measure and record pressure differences over the range 0-138 inches of water with a resolution of 0.03 inches of water. To measure the pressure differences, plastic tubing was run from the pressure logger to the appropriate spaces in the vacuum cleaners. This process involved drilling holes in the vacuum cleaner body, the vacuum cleaner hose, and in end caps for cartridge filters. The resulting holes were sealed with a flexible putty or duct tape.

Data collection involved the following steps:

1. The final filter was weighed and atmospheric pressure was recorded.
2. The vacuum cleaner was turned on. The initial air flow into the vacuum cleaner, was measured using the test apparatus described by Figure 5. The venturi meter pressure differential was used to compute the air flow as described elsewhere.¹⁷
3. After measuring the air flow, the venturimeter and pipe was disconnected from the apparatus shown in Figure 5. The following pressure measurements were made with the Smart Reader pressure loggers and static pressure measurements were made with the U-tube manometer: in the space between the final filter and the vacuum cleaner motor, and the static pressures upstream and downstream of each filter in the vacuum cleaner. For the Dust Control and Tiger Vac vacuum cleaner, the vacuum cleaner hose remained attached to the vacuum cleaner. For the Dust Director and Bosch vacuum cleaners, the vacuum cleaner hose was removed because it was impractical to insert a hose through both the vacuum cleaner hose and the inlet to the vacuum cleaner. Thus, we simply removed the vacuum cleaner hose and inserted the tubing for the static pressure measurements directly into the vacuum cleaner bag. After making this measurement, the hose was removed from the vacuum cleaner bag.
4. The mortar removal debris was in bucket that sat on a scale (Pelouze, model 4010 G, item 4TH71, Grainger Supply Company). The vacuum cleaner was turned on and the vacuum cleaner hose was to suck 5.0 ± 0.2 pounds of mortar debris into the vacuum cleaner.
5. The hose for measuring the pressure difference across the vacuum cleaner bag was placed back into the vacuum cleaner bag. The procedure described in steps 2 and 3 was used to measure the final air flow and pressures.
6. The vacuum cleaner was turned off and the final filter was cleaned, as recommended by the vacuum cleaner manufacturer. In the case of the DustDirector vacuum cleaner, we simply turned the vacuum cleaner on, while blocking the inlet with a flat block of wood, and simultaneously removing the block and turning the motor off.
7. Steps 2-6 were repeated until 35 pounds of debris were sucked into the vacuum cleaner. Then, the final filter was reweighed.

Data analysis

To obtain the vacuum cleaner fan curves, air flows were computed from the pressure differential across the venturi meter as described elsewhere.¹⁷ Regression analysis was used to fit the data to model described by equation 1. Regression analysis performed using the data analysis

tools in the 2007 Excel (Microsoft, Redmond WA). These vacuum cleaner fan curves were used to estimate air flow during filter pressure differential measurements. Air flow measurements with a venturi meter causes an additional pressure loss of 7% of the measured pressure differential for the venturi meter used in this study.¹⁹

This study was conducted to evaluate how debris accumulation affects the resistance to air flow for the filters with in a vacuum cleaner. The pressure differences across the vacuum cleaner filters were computed for each 5-pound increment of debris. The air flow was computed from the vacuum cleaner static pressures measured with the pressure transducer. Filter resistance, K_{filter} , was computed for each filter as described by equation 2. For each filter, the individual values of K_{filter} , were plotted as function cumulative mass debris transferred to the vacuum cleaner. In addition, regression analysis was performed which modeled K_{filter} as simple linear function of cumulative mass of debris transferred to the vacuum cleaner.

To examine the effect debris accumulation upon vacuum cleaner air flows, vacuum cleaner air flows were computed directly from the venturi meter pressure differentials.¹⁷ For each vacuum cleaner, air flows were plotted as function the cumulative mass of debris transferred to the vacuum cleaner. Regression analysis was performed which modeled vacuum cleaner air flow as simple linear function of cumulative mass of debris transferred to the vacuum cleaner.

RESULTS AND FINDINGS

The data are listed in the Appendices. Appendix A-D lists the data collected obtained for each vacuum cleaner. Appendix E presents data and analyses which shows that the pressure transducers measure an absolute pressure, at the inlet to the vacuum cleaner motor, that is equivalent to an absolute pressure obtained with the u-tube manometer and a barometer.

The vacuum cleaner fan curves are well described by the equation 1 as flow rate decreases linearly with increased vacuum cleaner static pressure. As listed in Table 3, the R^2 statistic for this model was better than 0.989 and the standard error of estimates for the four vacuum cleaners were between 1.3 and 2.7 cfm. The slope of the fan curve shows how flow decreases with increased vacuum cleaner static pressure. The impact of pressure loss upon air flow is simply the product of the slope and the pressure loss. The standard error of estimate for the slope is less than 4% slope. This variability is trivial compared to the variability in the pressure loss and filter resistance data that is presented latter in this report.

Table 3. Summary statistics describing vacuum cleaner fan curves.				
Regression statistics	Vacuum Cleaner			
	Tiger Vac	Dust Control 2700	Bosch	Dust director
Intercept (cfm)	90	120	119	119
Slope (cfm/inch of water)	-1.13	-1.43	-1.63	-1.32
Std error of estimate (cfm)	1.37	1.28	2.49	2.67
Std error, intercept (cfm)	0.61	0.81	1.56	2.39
Std error, slope (cfm/inch of water)	0.015	0.017	0.037	0.042
N	19	16	15	12
R ²	0.997	0.998	0.993	0.989

Table 4. Probability that chance explained the fit of the regression line to the data.					
Figure number	Dependent variable in Figure	Vacuum Cleaner			
		Tiger Vac	Dust Control 2700	Bosch	Dust Director
6	vacuum cleaner air flow before adding 5 pound increments	0.6037	0.4999	P< 0.0001	0.0003
	vacuum cleaner air flow after adding 5 pound increment	0.6987	0.2904	P< 0.0001	P< 0.0001
7	K, flow resistance for vacuum cleaner bag, after cleaning			P< 0.0001	0.0007
	K, flow resistance for vacuum cleaner bag, before cleaning			P< 0.0001	P< 0.0001
	K, flow resistance for filter between vacuum cleaner bag and final filter, before cleaning				0.0021
	K, flow resistance for filter between vacuum cleaner bag and final filter, after cleaning				0.0296
8	K, flow resistance for final filter after cleaning	0.0123	0.1945	P< 0.0001	P< 0.0001
	K, flow resistance for final filter before cleaning	0.0140	0.0723	P< 0.0001	0.0032

Note: Blank cell indicates that vacuum cleaner does not have this filter

The flow rate provided by the Tiger-Vac and the DustControl vacuum cleaners were largely unaffected by debris accumulation (Figures 6A and 6B). Debris accumulation had very little affect upon flow rate measured before and after cleaning the filters as values of R^2 were under 0.06 and this was not statistically significant (Table 4). The Tiger-Vac and the DustControl vacuum cleaners used cyclones in an effort to keep much of the debris before the air flows through the filters. In contrast, debris accumulation appears to affect the air flow provided by the Bosch and Dust Director vacuum cleaners (Figures 6C and 6D) and debris accumulation and this result was statistically significant as $P < 0.0003$ (Table 4). Furthermore, the slopes of the trend lines in these plots showed that these vacuum cleaners lost between 1.4 and 0.73 cfm per pound of debris accumulation (Figures 6C and 6D). As a result, air flows decreased from 80 to 30 cfm for the Bosch vacuum cleaner (Figure 6C) and from 70 to as low as 30 cfm for the Dust Director vacuum cleaner (Figure 6D).

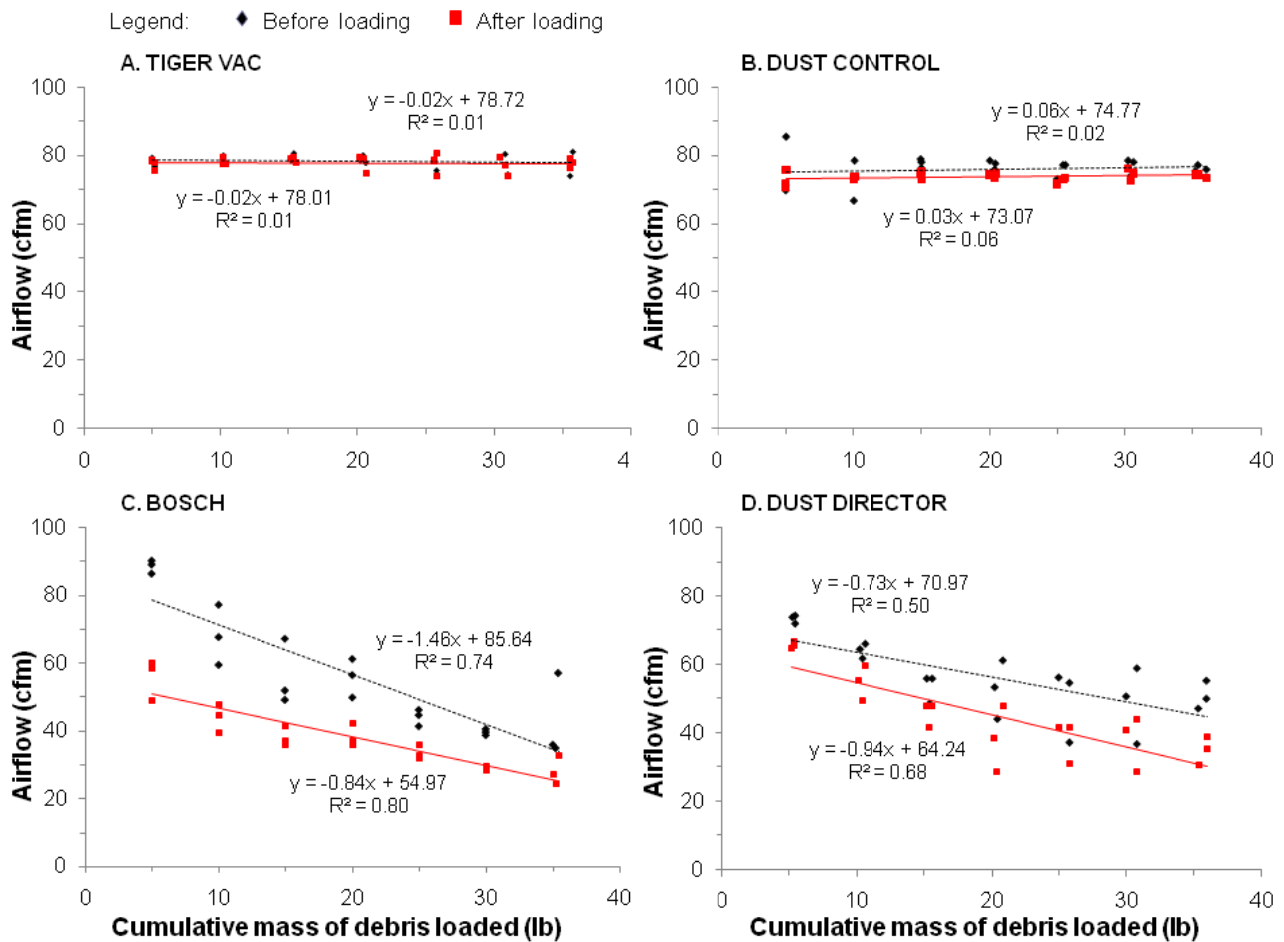

Figure 6. Airflow as a function of cumulative mass of debris sucked into the vacuum cleaner. Measurements were made before and after loading 5 lb of debris into the vacuum cleaner.

The flow rate decreases for the vacuum cleaners which used vacuum cleaner bags, the Bosch and Dust Director vacuum cleaners, are quite noticeable (Figure 6) and are statistically significant ($P < 0.0003$ in Table 4). The resistance to air flow by the vacuum cleaner bags and prefilters increases noticeably with debris accumulation (Figure 7) and the difference was significant ($P < 0.0007$ in Table 4). Before sucking debris into the vacuum cleaner bags and pre-filters, the resistance to air flow is actually under 0.1 inches of water per cfm. With increasing debris accumulation, the resistance to air flow by the vacuum cleaner bags can exceed 1.9 inches of water/cfm. At air flows of 30 cfm, this is a filter pressure loss of 57 inches of water. Based upon the slope of the vacuum cleaner fan curves for the Bosch and Dust Director vacuum cleaners (Table 3), a 57 inch of water pressure would cause the vacuum cleaner air flows to decrease by 91 and 74 cfm, respectively. With no pressure loss, these vacuum cleaners provide an air flow of 119 cfm (the intercepts for the fan curves listed in Table 1.) Considering only the pressure loss caused by the vacuum cleaner bags, the flow moved by the Bosch and the Dust Director vacuum cleaners is estimated to be under 27 and 43 cfm, respectively. Clearly, increased pressure loss through the vacuum cleaner bags explains why the Bosch and the Dust Director vacuum cleaners lose air flow with increased debris accumulation.

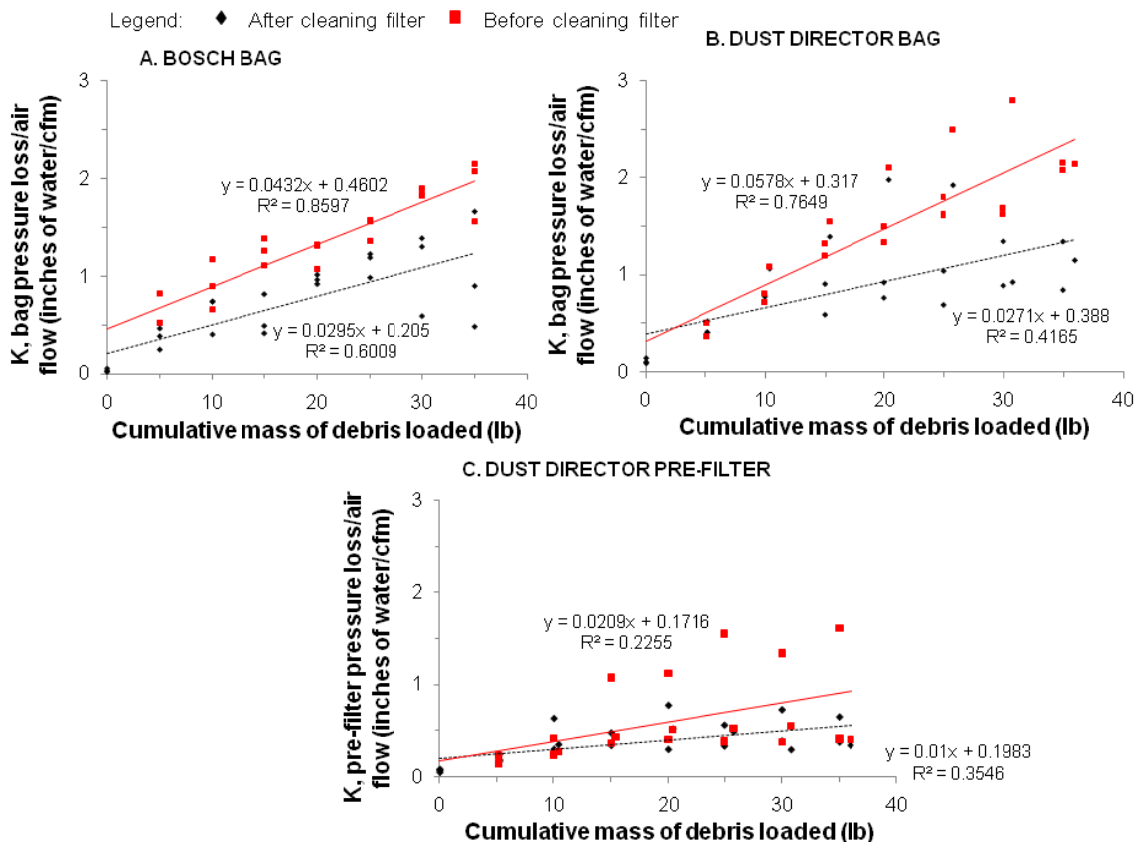

Figure 7. Flow rate resistance for pre-filters into Bosch (8A) and Dust Director (8B and 8C) vacuum cleaners. These measurements were made before and after cleaning the filters when adding 5 cumulative lb of debris.

The filter resistance for final filters in each vacuum cleaner was not as high as the resistance found for bags and for pre-filters in Bosch and Dust Director vacuum cleaners. Figure 8 shows that the filter resistances do not increase dramatically with cumulative mass of debris loaded into each vacuum cleaner. The slopes for the trend lines in Figure 8 are smaller than 0.0013 inches of water/cfm/pound of debris accumulation. This indicates that the resistance to air flow for the final filters is gradually increasing and these filters will eventually need to be changed.

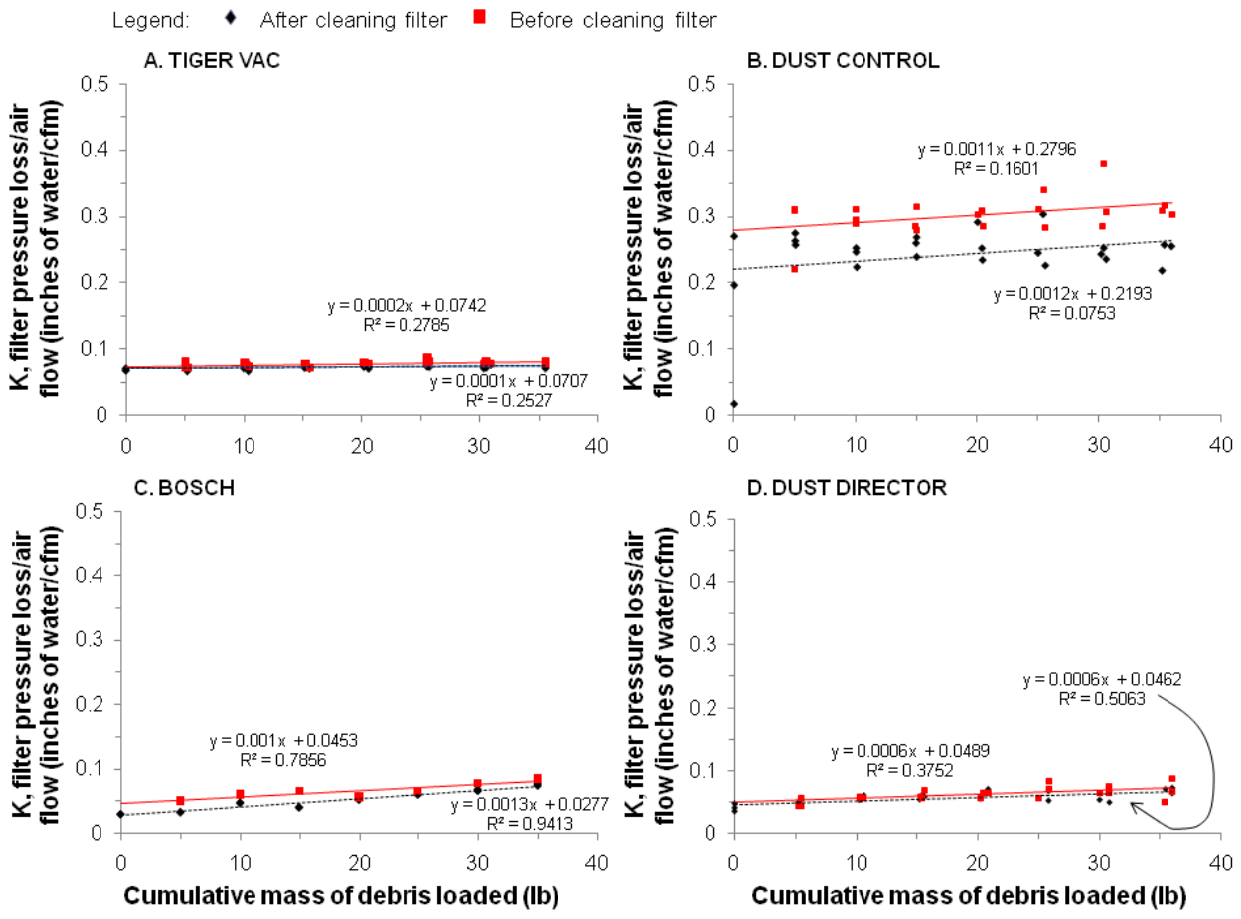

Figure 8. Filter pressure loss/airflow for each vacuum cleaner. These measurements were made before and after cleaning the filters when adding 5 cumulative lb of debris.

DISCUSSION

Vacuum cleaners with cyclones provided a more stable airflow and were not affected by debris accumulation. These vacuum cleaners provided airflow between 78 and 73 cfm (Figure 6A and 6B). Debris accumulation can dramatically increase the resistance to air flow through vacuum cleaner bags (Figure 7A and 7B) and cause airflows to decrease from 85 to 30 cfm (Figures 6C and 6D). Apparently vacuum cleaners with vacuum cleaner bags should only be used for applications where 30 cfm provides adequate dust control. These data were generated with debris collected at a construction site. This may have allowed the powder to agglomerate. Clearly, field data would be useful to verify the conclusions of the laboratory study. However, the pressure losses through the vacuum cleaner bags clearly explain the air flow losses that were reported by Collingwood and Heitbrink.¹⁰

As documented in Table 2, the vacuum cleaners with cyclones cost about \$1500 and vacuum cleaners with bags cost about \$400 for the Bosch and \$800 for the Dust Director vacuum cleaners. However, the vacuum cleaner bags can be an important operating cost because they need to be changed about 2-3 times per day after collecting 10 to 15 lb of debris. The cost for the vacuum cleaner bags are \$5 per bag for the Dust Director vacuum cleaner.²⁰ The list price for a package of 5 Bosch vacuum cleaner bags is \$38.38 and the advertised price is \$28.99.²¹ Therefore, the vacuum cleaner bags cost at least \$5 per bag. To maintain airflow the workers will need to change out the vacuum cleaner bags at least twice per day. The capital cost difference for using a vacuum cleaner with a cyclone and the Bosch vacuum cleaner will be \$1100. The payback time of this capital cost is about 110 days of grinding. The actual payback time will depend upon the operation. Clearly, the higher capital cost vacuum cleaners will be more cost-effective if the service life is longer than 110 days of grinding. The payback time may be less than a construction season. Thus, contractors should consider using the higher cost vacuum cleaners to protect the workers health and to reduce operating cost. Health and safety professionals should use this payback time to promote the use of cyclonic vacuum cleaners.

The vacuum cleaners should include vacuum cleaner static pressure gauges so that workers can track the vacuum cleaner airflow. Gauges that measure pressure differential of 100" of water cost \$48.²² Workers should be trained on how to interpret this vacuum cleaner static pressure. When static pressure is too low workers need to take action to recover airflow. For vacuum cleaners with vacuum cleaner bags, the workers need to know when to change these bags to maintain airflow. Airflow requirements will actually vary depending on the type of job being done and there should be minimum air flow rate for each type of dust generating task such as mortar removal, concrete grinding, concrete drilling, ect.¹

Because vacuum cleaner bags caused decreased flow rates and increased work place dust exposure, researchers and practitioners should measure and log or record flow rates during actual debris accumulation. Such results are needed to develop an overall plan to control the worker's dust exposure. These recommendations include the frequency in which the worker

needs to stop and address flow rate decreases by pulsing filters or changing vacuum cleaner bags.

CONCLUSION

When much debris is being generated during tasks such as mortar grinding, cyclones should be used as the first stage of filtration. Cyclones can keep the debris accumulation from clogging filters and help the vacuum cleaner maintain air flow. Debris accumulation in vacuum cleaner bags caused pressure losses that were nearly 57 inches of water and this excessive pressure loss reduced the air flow provided by the vacuum cleaners.

BIBLIOGRAPHY

1. Flanagan ME, Seixas N , Becker P, Takacs B, Camp J: Silica Exposure on Construction Sites: Results of an Exposure Monitoring Data Compilation Project, *Journal of Occupational and Environmental Hygiene*, 3: 144–152 (2006)
2. Linch KD, M.W., Althouse RB, Groce DW, Hale JM: Surveillance of respirable crystalline silica dust using OSHA compliance data (1979-1995). *Am J Ind Med*, 34: 547-558 (1998).
3. NIOSH (2005): NIOSH Pocket Guide to Chemical Hazards. CDC (NIOSH) publication Publication No. 2005-151. Cincinnati Ohio Viewed on November 6th at: <http://www.cdc.gov/niosh/npg/npgd0553.html>.
4. NIOSH (2002): Health Effects of Occupational Exposure to Respirable Crystalline Silica. DHHS (NIOSH) Publication No. 2002-129. Cincinnati Ohio.
5. American Conference of Governmental Industrial Hygienists (2006): 2006 TLVs and BEIs Based on the Documentation of the Threshold Limit Values for Chemical Substances and Physical Agents & Biological Exposure Indices. Cincinnati Ohio.
6. ACGIH (2006): Documentation of the TLVS – Silica, Crystalline: alpha quartz and Cristobalite. Cincinnati Ohio: ACGIH Publications Office, 17 pp.
7. Steenland K; Sanderson W (2001): Lung cancer among industrial sand workers exposed to crystalline silica. *Am J Epidemiol* 153:695–703 (2001).

-
8. Heitbrink WA and Bennett (2006): A Numerical and Experimental Investigation of Crystalline Silica Exposure Control During Tuck-Pointing. *Journal of Occupational and Environmental Hygiene*, 3: 366–378.
 - 9 . American Conference of Governmental Industrial Hygienists (2006): *Industrial Ventilation – A Manual of Recommended Practice*. 26th edition, Cincinnati Ohio.
 10. Collingwood S, Heitbrink WA (2007): Field Evaluation of an Engineering Control for Respirable Crystalline Silica Exposures During Mortar Removal. Accepted for publication, February 12, 2007, *Journal of Occupational and Environmental Health*.
 11. Nij ET, Hilhorst S, Spee T, Spierings J, Steffens F, Lumens M, Heederik D (2003): Dust Control Measures in the Construction Industry. *Ann. occup. Hyg.*, Vol. 47: 211–218, 2003.
 12. Soderberg G.(1987): *Handbook for Planning and Dimensioning of Spot Extraction*. Norsborg Sweden: DustControl.
 - 13 . Nevers DE (1995): *Air pollution control Engineering*. New York: McGraw Hill. P. 232.
 - 14 . Hinds WC (1999): *Aerosol Technology-Properties, Behavior, and Measurement of Airborne Particles*. New York: John Wiley and Sons.
 - 15 . Collingwood SC (2006): *Research to practice :evaluations and recommendations for local exhaust ventilation designed to reduce respirable crystalline silica and dust exposures experienced during mortar removal*. Ph. D. Thesis, University of Iowa. Hardin Library For Health Sci Thesis T2006 .C779. Iowa City.

-
- 16 . Halmi D (1974): Metering Performance Investigation and Substantiation of the Universal Venturi Tube. Part 1 Hydraulic Shape and Discharge Coefficient Transactions of ASME –Journal of Fluids Engineering. 96(2):124-138.
 17. International Standards Organization (2003): ISO 5167-4 Measurement of fluid flow by means of a pressure differential device inserted in the circular cross-section conduits running full- Part 4: Venturi Tubes. Case postale 56, CH-1211 Geneva 20, Switzerland.
 18. International Standards Organization (2003): ISO 5167-4: Measurement of fluid flow by means of a pressure differential device inserted in the circular cross-section conduits running full- Part 4: Venturi Tubes. Case postale 56, CH-1211 Geneva 20, Switzerland.
 - 19 . Miller RW (1988): Flow Measurement Engineering Handbook. 2nd ed. New York: McGraw Hill, page 6-30.
 20. Masonry / Concrete Ultra-Fine Dust Extraction Vacuum. Viewed on April 8th 2008 at: http://www.icscompany.net/DCVAC_Contractor.htm
 21. Bosch Vaccum Dust Bags (Pack of 5). Viewed on April 8th 2008 at: <http://www.amazon.com/Bosch-Vaccum-Dust-Bags-Pack/dp/B0000AV7AW>
 - 22 . Grainger 2008-2009 catalog 399. W.W. Grainger Inc. Lake Forest, Ill. Page 749.

CONTENT OF THE APPENDICIES

APPENDIX A. Data from Tiger Vac Vacuum Cleaner.....	29
Figure A-1. Location of static pressure measurements on the Tiger Vac vacuum cleaner.	30
Table A1. Fan curve air flow through Tiger Vac vacuum Cleaner 12/06/2007.....	31
Table A2. Environmental Conditions and final filter weights.....	32
Table A3. Pressure losses and air flows through Tiger Vac vacuum cleaner 11/09/2007 Round 1	33
Table A4. Pressure losses and air flows through Tiger Vac vacuum cleaner 11/13/2007 Round 2	34
Table A5. Pressure losses and air flows through Tiger Vac vacuum cleaner 11/13/2007 Round 3	35
APPENDIX B. Data from DustControl 2700 Vacuum Cleaner	36
Figure B-1. Location of static pressure measurements for DustControl 2700 vacuum cleaner.....	37
Table B1. Fan curve air flow through DustControl vacuum Cleaner 08/30/2007	38
Table B2. Weight gain of filter filter and test conditions.	39
Figure B-2. Fan curve for DustControl 2700 Vacuum Cleaner.....	39
Table B3. Pressure loss and air flows through DustControl 2700 Vacuum Cleaner 09/07/2007 Round 1	40
Table B4. Pressure losses and air flows through DustControl 2700 vacuum cleaner: 09/13/2007 Round 2	41
Table B5. Pressure losses and air flows through DustControl 2700 vacuum cleaner: 09/13/2007 Round 3	42
APPENDIX C. Data from Bosch Vacuum Cleaner	43
Figure C-1. Locations for measuring pressures in Bosch vacuum cleaner.	44
Table C1. Fan curve air flow through Bosch vacuum Cleaner 08/30/2007	45
Figure C-2. Fan curve for Bosch vacuum cleaner.	46
Table C2. Filter weights and environmental conditions.....	47
Table C3. Pressure loss and air flows through Bosch vacuum Cleaner 9/14/2007 Round 1	48
Table C4. Pressure loss and air flows through Bosch vacuum Cleaner 9/14/2007 Round 2	49
Table C5. Pressure loss and air flows through Bosch vacuum Cleaner 9/14/2007 Round 2	50
APPENDIX D. Data for Dust Director Vacuum Cleaner Fan Curve (serial number PO7F14792)51	
Figure D-1. Locations for measuring static pressures inside the Dust Director vacuum cleaner.....	52

Table D1. Fan curve air flow through Dust Director vacuum Cleaner 08/30/2007.....	53
Figure D-2. Fan curve for Dust Director vacuum cleaner.....	54
Table D2. Filter weights and environmental conditions.....	55
Table D3. Pressure loss and air flows through Dust Director vacuum cleaner 10-04-2007 Round 1	56
Table D4. Pressure loss and air flows through Dust Director vacuum cleaner 10-04-2007 Round 2	57
Table D5. Pressure loss and air flows through Dust Director vacuum cleaner 10-11-2007 Round 3	58
APPENDIX E. Comparison of absolute pressures and pressures obtained from pressure transducers.....	59
Table E1. Comparison of pressures.....	61
Table E2. Regression analyses for predicting actual pressures from pressure transducer response.....	62

APPENDIX A. Data from Tiger Vac Vacuum Cleaner.



Ho
pre
filt



Figure A-1. Location of static pressure measurements on the Tiger Vac vacuum cleaner.

Table A1. Fan curve air flow through Tiger Vac vacuum Cleaner 12/06/2007

Static pressure (difference from atmospheric pressure) in inches of water	Venturimeter Pressure Difference (inches of wáter)	Vacuum cleaner Air flow (cfm)
80.2	0	0.00
62.4	0.35	15.15
59.9	0.6	19.96
56.8	0.9	24.57
53.9	1.25	29.08
51.3	1.5	31.93
47.6	1.9	36.04
43.5	2.45	41.03
39.7	3.15	46.63
33.3	4	52.63
29.4	4.8	57.69
24	5.75	63.15
19.85	6.6	67.64
16	7.45	71.84
13.9	7.7	73.02
11.85	8.1	74.87
10.9	8.4	76.17
9	9	78.81
7.8	9.5	80.93

Table A2. Environmental Conditions and final filter weights				
	Barometric Pressure (mm of Hg)	Temperature (Celsius degrees)	Weight of filter before adding 35 lb of debris (grams)	Weight of filter after adding 35 lb of debris (grams)
Round 1 11/09/2007	745.3	20	2171	2306
Round 2 11/13/2007	739.0	22.2	2265	2310
Round 3 11/13/2007	739.0	22.2	2306	2357

Table A3. Pressure losses and air flows through Tiger Vac vacuum cleaner 11/09/2007 Round 1

Before (B) or after (A) adding 5 pounds of debris	Total weight of debris transferred into vacuum cleaner (lb)	Venturi meter ΔP (inches of water)	Static Pressure Measurements made with manometer (inches of water) ¹			Absolute pressure measured with pressure transducers (psi)		Time measuring before loading	Time measuring during loading	Air flow (cfm) from venturi meter
			Pressure in the hose (inches of water)	Pressure before the filter (inches of water)	Pressure after the final filter (inches of water)	Pressure before the filter (psi) 53748	Pressure after the filter (psi) 55481			
B	5	9.1	-4.3	-5	-5.45	14.032	14	4:45pm	4:47pm	79.29
A		8.9	-4.45	-4.95	-5.7	14.024	13.984			78.43
B	10.2	8.8	-4.2	-4.9	-5.65	14.032	13.992	4:55pm	4:57pm	77.99
A		9.1	-4.4	-4.9	-6	14.032	13.984			79.29
B	15.2	8.9	-4.25	-4.8	-5.85	14.04	13.984	5:05pm	5:06pm	78.43
A		9	-4.3	-4.8	-6.15	14.049	13.975			78.86
B	20.2	8.9	-4.2	-4.7	-6	14.049	13.984	5:12pm	5:14pm	78.43
A		9.1	-4.25	-4.75	-6.4	14.04	13.967			79.29
B	25.6	8.9	-4.3	-4.7	-6.25	14.057	13.967	5:20pm	5:22pm	78.43
A		8.9	-4.4	-5	-6.9	14.032	13.958			78.43
B	30.4	9.1	-4.4	-5.2	-6	14.032	13.984	5:27pm	5:30pm	79.29
A		9.1	-4.1	-4.7	-6.15	14.04	13.975			79.29
B	35.6	8.75	-4.1	-4.9	-5.6	14.032	13.984	5:36pm	5:39pm	77.77
A		9	-4.2	-4.85	-6.2	14.049	13.967			78.86
Final	35.6	9.25	-4.2	-4.9	-5.75	14.032	13.984	5:46pm		79.93

¹ Static pressure is the difference in pressure from atmospheric pressure. Negative static pressure indicates that pressure is less than atmospheric pressure.

Table A4. Pressure losses and air flows through Tiger Vac vacuum cleaner 11/13/2007 Round 2

Before (B) or after (A) adding 5 pounds of debris	Total weight of debris transferred into vacuum cleaner (lb)	Venturi meter ΔP (inches of water)	Static Pressure Measurements made with manometer (inches of water) ¹			Absolute pressure measured with pressure transducers (psi)		Time measuring before loading	Time measuring during loading	Air flow (cfm) from venturi meter
			Pressure in the hose (inches of water)	Pressure before the filter (inches of water)	Pressure after the final filter (inches of water)	Pressure before the filter (psi) 53748	Pressure after the filter (psi) 55481			
B	5.2	8.8	-4.5	-4.9	-5.4	13.882	13.84	2:59pm	3:00pm	77.99
A		8.75	-4.3	-4.7	-5.6	13.89	13.824			77.77
B	10.4	8.7	-4.15	-4.6	-5.25	13.89	13.84	3:05pm	3:07pm	77.55
A		8.65	-4.3	-4.6	-5.65	13.89	13.832			77.33
B	15.6	8.8	-4.3	-4.6	-5.3	13.89	13.84	3:12pm	3:14pm	77.99
A		8.8	-4.25	-4.6	-5.6	13.882	13.824			77.99
B	20.6	8.75	-4.2	-4.6	-5.55	13.882	13.824	3:23pm	3:25pm	77.77
A		8.1	-4.2	-4.5	-5.8	13.882	13.815			74.87
B	25.8	8.25	-4.3	-4.5	-5.4	13.873	13.84	3:37pm	3:38pm	75.55
A		7.9	-4.5	-4.85	-6	13.865	13.815			73.95
B	31	8	-4.3	-4.8	-5.5	13.865	13.815	3:43pm	3:46pm	74.41
A		7.9	-4.35	-4.5	-5.75	13.865	13.824			73.95
B	35.6	7.9	-4.4	-4.8	-5.7	13.865	13.824	3:52pm	3:56pm	73.95
A		8.4	-4.5	-4.8	-6.25	13.857	13.807			76.22
Final	35.6	8.2	-4.4	-4.8	-5.6	13.731	13.8	4:02pm		75.32

¹ Static pressure is the difference in pressure from atmospheric pressure. Negative static pressure indicates that pressure is less than atmospheric pressure.

Table A5. Pressure losses and air flows through Tiger Vac vacuum cleaner 11/13/2007 Round 3

Before (B) or after (A) adding 5 pounds of debris	Total weight of debris transferred into vacuum cleaner (lb)	Venturi meter ΔP (inches of water)	Static Pressure Measurements made with manometer (inches of water) ¹			Absolute pressure measured with pressure transducers (psi)		Time measuring before loading	Time measuring during loading	Air flow (cfm) from venturi meter
			Pressure in the hose (inches of water)	Pressure before the filter (inches of water)	Pressure after the final filter (inches of water)	Pressure before the filter (psi) 53748	Pressure after the filter (psi) 55481			
B	5.2	8.5	-4.3	-4.6	-5.5	13.848	13.807	5:28	5:30	76.67
A		8.2	-4.3	-4.8	-6.1	13.832	13.748			75.32
B	10.2	9.25	-4.4	-4.85	-5.8	13.84	13.781	5:35	5:36	79.93
A		8.7	-4.5	-4.8	-6.2	13.848	13.756			77.55
B	15.4	9.4	-4.65	-4.75	-5.8	13.832	13.79	5:40	5:43	80.56
A		9.1	-4.3	-4.7	-6.1	13.848	13.781			79.29
B	20.4	9.25	-4.4	-4.9	-5.8	13.848	13.781	5:47	5:49	79.93
A		9.05	-4.5	-4.8	-6.15	13.848	13.773			79.07
B	25.8	9.35	-4.35	-4.85	-5.95	13.832	13.79	5:54	5:56	80.35
A		9.4	-4.4	-4.8	-6.3	13.832	13.773			80.56
B	30.8	9.35	-4.4	-4.85	-6	13.832	13.781	6:01	6:03	80.35
A		8.6	-4.5	-4.9	-6.3	13.84	13.748			77.11
B	35.8	9.5	-4.2	-4.9	-5.9	13.832	13.781	6:07	6:10	80.98
A		8.8	-4.45	-4.8	-6.3	13.832	13.748			77.99
Final	35.8	9.65	-4.5	-5	-6.05	13.832	13.781	6:15		81.61

¹ Static pressure is the difference in pressure from atmospheric pressure. Negative static pressure indicates that pressure is less than atmospheric pressure.

APPENDIX B. Data from DustControl 2700 Vacuum Cleaner

B. Static pressure measurements in cyclone



A. Static pressure measurements in vacuum cleaner body.

Static pressures were measured along the wall of the body of the vacuum cleaner and inside the vacuum cleaners cartridge filter.

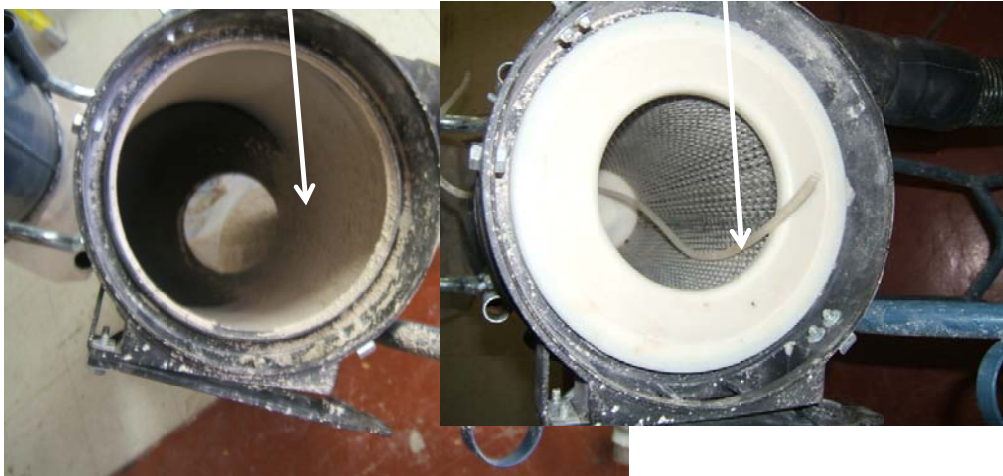

Figure B-1. Location of static pressure measurements for DustControl 2700 vacuum cleaner.

Table B1. Fan curve air flow through DustControl vacuum Cleaner 08/30/2007

Static pressure (difference from atmospheric pressure) in inches of water ¹	Absolute pressure in vacuum cleaner pressure in (psia) ²	Absolute pressure, (Pressure transducer 55481) (psia)	Absolute Pressure (Pressure transducer data 53748) (psia)	Venturimeter pressure differential (inches of water)	Absolute pressure from the manometer (psia) ¹	vacuum cleaner air flow (cfm)
0	14.46	14.287	14.316	0	0.00	0.00
69.1	11.95	11.752	11.793	0	2.51	0.00
61.4	12.23	12.030	12.060	0.23	2.23	12.23
54.3	12.49	12.300	12.328	0.81	1.97	23.28
46.2	12.78	12.586	12.629	1.85	1.68	35.55
41.5	12.95	12.771	12.796	2.62	1.51	42.46
36.3	13.14	12.965	12.979	3.6	1.32	49.90
31	13.33	13.133	13.172	4.5	1.13	55.85
27.2	13.47	13.285	13.305	5.45	0.99	61.48
24.2	13.58	13.403	13.431	6.4	0.88	66.62
20.7	13.71	13.520	13.548	7.4	0.75	71.60
17.3	13.83	13.638	13.665	8.4	0.63	76.22
14.9	13.92	13.731	13.739	9.1	0.54	79.29
13	13.99	13.798	13.823	9.8	0.47	82.23
8	14.17	13.984	13.999	11.4	0.29	88.54
6	14.24	14.051	14.066	12.3	0.22	91.89
Barometric Pressure: 747.5 mm of Hg						
Temperature 25 °C						
¹ Absolute pressure is the difference between the barometric pressure and the U-tube pressure.						
² Absolute pressure in pounds per square inch.						

Table B2. Weight gain of filter filter and test conditions.				
	Barometric Pressure (mm of Hg)	Temperature (°C)	Weight of filter before adding 35 lb of debris (grams)	Weight of filter after adding 35 lb of debris (grams)
Round 1 09/07/2007	736.5	24.5	768	907
Round 2 09/13/2007	741.5	24.3	863	864
Round 3 09/13/2007	741.5	24.3	864	848 ¹

1. This was filter that had been at job sites. The debris fell off on the way to the scale.

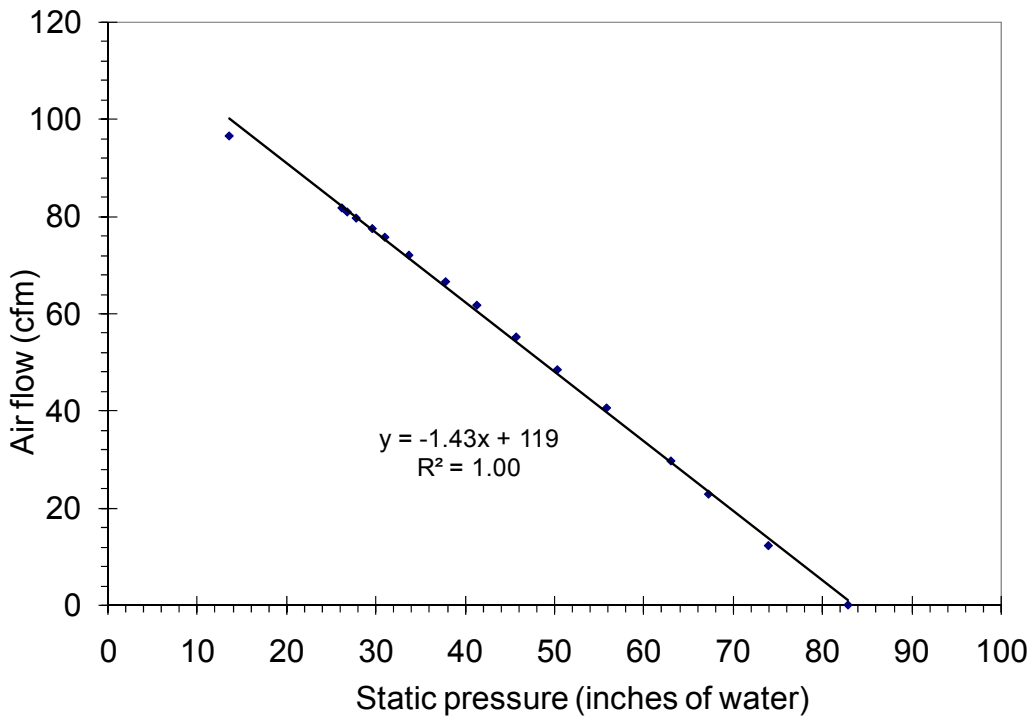

Figure B-2. Fan curve for DustControl 2700 Vacuum Cleaner.

Table B3. Pressure loss and air flows through DustControl 2700 Vacuum Cleaner 09/07/2007 Round 1

Before (B) or after (A) adding 5 pounds	Total weight added to vacuum cleaner (lb)	Venturi meter ΔP (inches of water)	Static Pressure Measurements made with manometer (inches of water) ¹			Absolute pressure measured with pressure transducers.(psia)		Time to start loading	Time to stop loading	Filter pressure loss inches of water, corrected for calibration curve of the pressure transducers	Air flow from venturi meter (cfm)
			Upstream "before cyclone"	Downstream "after cyclone"	ΔP	Upstream of final filter (55481)	Downstream of filter at inlet to vacuum cleaner motor. (53478)				
B	5.025	10.6	-7.1	-13	5.9	13.52	13.489	10:23am	10:25am	1.39	85.45
A		8.3	-5.6	-6.4	0.8	13.79	13.205			16.7	75.78
B	5.03	8.9	-4.3	-6.4	2.1	13.807	13.096	10:43am	10:45am	20.2	78.43
A		7.9	-3.9	-5.9	2	13.824	13.013			22.9	73.95
B	4.895	9	-4.4	-6.7	2.3	13.807	13.188	10:54am	10:56am	17.6	78.86
A		8.1	-4	-5.9	1.9	13.807	13.055			21.3	74.87
B	5.4	8.3	-4.4	-6.3	1.9	13.815	13.121	11:07am	11:09am	19.7	75.78
A		7.8	-3.8	-5.5	1.7	13.84	13.038			22.7	73.49
B	5.075	8.6	-4.4	-5.8	1.4	13.832	13.147	11:18am	11:20am	19.5	77.11
A		7.7	-3.3	-5.4	2.1	13.824	12.946			24.8	73.02
B	4.975	7.9	-3.9	-6.2	2.3	13.84	13.046	11:42am	11:44am	22.4	73.95
A		7.6	-3.6	-5.3	1.7	13.874	12.896			27.5	72.55
B	4.985	8.6	-4.1	-6	1.9	13.807	13.121	11:56am	11:58am	19.5	77.11
A		8	-3.7	-5.5	1.8	13.84	13.005			23.6	74.41
Final		7.5	-3.8	-6.9	3.1	13.807	13.155	12:08pm		18.54	72.07

¹ Static pressure is the difference in pressure from atmospheric pressure. Negative static pressure indicates that pressure is less than atmospheric pressure.

Table B4. Pressure losses and air flows through DustControl 2700 vacuum cleaner: 09/13/2007 Round 2

Before (B) or after (A) adding 5 pounds	Total weight added to vacuum cleaner (lb)	Venturi meter ΔP (inches of water)	Static Pressure Measurements with manometer (inches of water) ¹			Absolute pressures measured with pressure transducers.(psi)		Time to start loading	Time to stop loading	Filter pressure loss inches of water, corrected for calibration curve of the pressure transducers	Air flow from venturi meter (cfm)
			Upstream "before cyclone"	Downstream "after cyclone"	ΔP	Upstream of final filter (55481)	Downstream of filter at inlet to vacuum cleaner motor (53478)				
B	5	7.3	-4	-8	4	13.824	13.147	12:53 pm	12:56pm	19.23	71.12
A		7.2	-3.8	-5.8	2	13.899	13.13			21.77	70.63
B	5	7.7	-4.4	-6.9	2.5	13.874	13.197	1:00pm	1:02pm	19.22	73.02
A		7.7	-4.2	-6.2	2	13.891	13.13			21.55	73.02
B	5	8.8	-4.4	-6.2	1.8	13.874	13.18	1:15pm	1:17pm	19.69	77.99
A		7.7	-4.1	-6.3	2.2	13.891	13.08			22.93	73.02
B	5	8.9	-3.9	-6.2	2.3	13.874	13.13	1:26pm	1:27pm	21.08	78.43
A		8	-4.1	-6.3	2.2	13.883	13.088			22.49	74.41
B	5	7.7	-4.3	-10	5.7	13.84	13.088	2:00pm	2:02pm	21.30	73.02
A		7.4	-4.1	-6.1	2	13.857	13.071			22.24	71.60
B	5.2	8.9	-5.1	-7.1	2	13.849	13.172	2:08pm	2:10pm	19.23	78.43
A		8.4	-4.4	-7	2.6	13.857	13.088			21.77	76.22
B	5	8.2	-4.5	-6.6	2.1	13.849	13.205	2:16pm	2:18pm	18.31	75.32
A		8	-4.5	-6.4	1.9	13.866	13.055			22.93	74.41
Final		8.7	-4.6	-6.7	2.1	13.832	13.238	2:22pm		16.93	77.55

¹ Static pressure is the difference in pressure from atmospheric pressure. Negative static pressure indicates that pressure is less than atmospheric pressure.

Table B5. Pressure losses and air flows through DustControl 2700 vacuum cleaner: 09/13/2007 Round 3

Before (B) or after (A) adding 5 pounds	Total weight added to vacuum cleaner (lb)	Venturi meter ΔP (inches of water)	Static Pressure Measurements with manometer (inches of water) ¹			Absolute pressures measured with pressure transducers. (psi)		Time to start loading	Time to stop loading	Filter pressure loss inches of water, corrected for calibration curve of the pressure transducers	Air flow from venturi meter (cfm)
			Upstream "before cyclone"	Downstream "after cyclone"	ΔP	Upstream of final filter (55481)	Downstream of filter at inlet to vacuum cleaner motor (53478)				
B	5	7	-3.4	-12.5	9.1	13.622	13.147	3:32pm	3:34pm	13.67	69.65
A		7.4	-4	-6.4	2.4	13.84	13.055			22.22	71.60
B	5	6.4	-4.6	-6.6	2	13.824	13.18	3:39pm	3:41pm	18.32	66.62
A		7.8	-4.4	-6.6	2.2	13.832	13.08			21.31	73.49
B	5	8.4	-4.9	-6.9	2	13.824	13.163	3:47pm	3:48pm	18.79	76.22
A		8.2	-4.5	-6.4	1.9	13.84	13.096			21.08	75.32
B	5.4	8.7	-5.1	-7.5	2.4	13.815	13.163	3:53pm	3:55pm	18.54	77.55
A		8.1	-4	-6.4	2.4	13.832	13.08			21.31	74.87
B	5.2	8.6	-4.6	-7	2.4	13.798	13.163	4:00pm	4:02pm	18.07	77.11
A		7.8	-4.2	-6.5	2.3	13.824	13.088			20.86	73.49
B	5	8.8	-4.5	-6.7	2.2	13.807	13.188	4:08pm	4:11pm	17.63	77.99
A		8.1	-3.9	-6.3	2.4	13.84	13.03			22.91	74.87
B	5.4	8.3	-4.2	-6.9	2.7	13.807	13.18	4:18pm	4:20pm	17.85	75.78
A		7.8	-3.8	-6.5	2.7	13.824	13.038			22.25	73.49
Final		8.4	-4.3	-6.7	2.4	13.815	13.13	4:26pm		19.45	76.22

¹ Static pressure is the difference in pressure from atmospheric pressure. Negative static pressure indicates that pressure is less than atmospheric pressure.

APPENDIX C. Data from Bosch Vacuum Cleaner

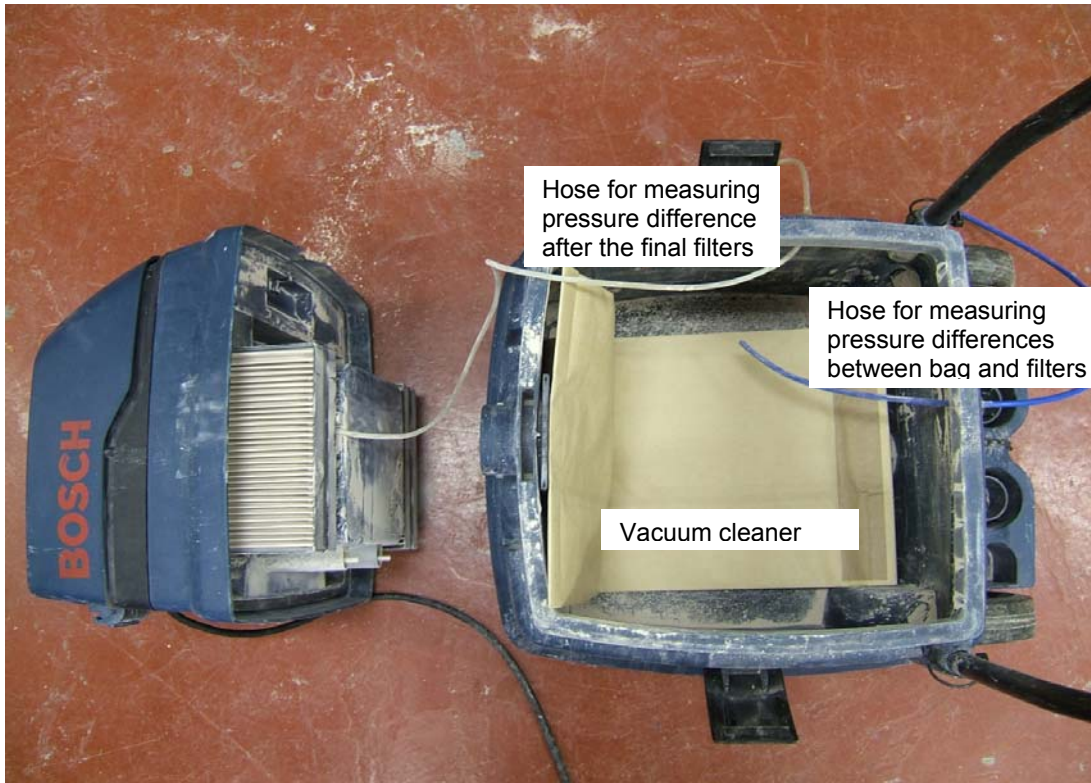

Figure C-1. Locations for measuring pressures in Bosch vacuum cleaner.

Table C1. Fan curve air flow through Bosch vacuum Cleaner 08/30/2007

Static pressure (difference from atmospheric pressure) in inches of water	Absolute Pressure at inlet to vacuum cleaner motor estimated from static pressure ¹ (psia)	Absolute Pressure from transducer 55481 (psia)	Absolute Pressure from transducer 53748 (psia)	Venturimeter Pressure difference (inches of water)	Vacuum cleaner air flow from venturi meter (cfm)
70.8	11.88	11.685	11.701	0	0.00
64.2	12.12	11.921	11.943	0.24	12.49
57.8	12.35	12.157	12.161	0.82	23.43
53.9	12.50	12.291	12.328	1.5	31.93
49.4	12.66	12.476	12.478	2.35	40.17
44.8	12.83	12.62	12.654	3.35	48.11
41.5	12.95	12.746	12.771	4.35	54.90
37.5	13.09	12.881	12.904	5.4	61.20
32.7	13.27	13.066	13.088	6.65	67.90
30.1	13.36	13.15	13.172	7.4	71.60
26.7	13.48	13.285	13.297	8.4	76.22
24.6	13.56	13.361	13.38	9.1	79.29
22.4	13.64	13.445	13.447	9.8	82.23
16.9	13.84	13.638	13.665	11.8	90.05
8.2	14.15	13.967	13.99	15	101.06

¹ Absolute pressure is the difference between the barometric pressure and the U-tube pressure.

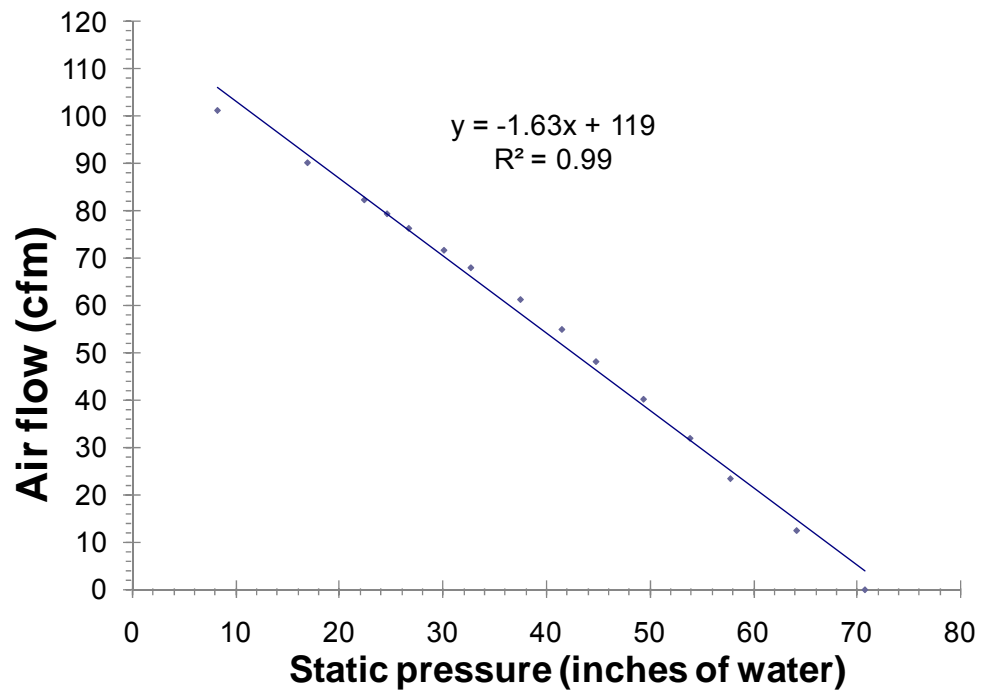

Figure C-2. Fan curve for Bosch vacuum cleaner.

Table C2. Filter weights and environmental conditions.							
	Barometric Pressure (mm of Hg)	Temperature (Celsius degrees)	Weight of filter 1 before adding 35 lb of debris (grams)	Weight of filter 1 after adding 35 lb of debris (grams)	Weight of filter 2 before adding 35 lb of debris (grams)	Weight of filter 2 after adding 35 lb of debris (grams)	Final weight of the vacuum cleaner bag (lb)
Round 1 09/14/2007	743.6	23.2	438	439	439	440	35.2
Round 2 09/14/2007	743.6	23.2	439	439	440	441	36.2
Round 3 09/20/2007	745.1	24	439	442	441	442	35.2

Table C3. Pressure loss and air flows through Bosch vacuum Cleaner 9/14/2007 Round 1

Before (B) or after (A) adding 5 pounds	Total weight of debris transferred (lb)	Venturi meter ΔP (inches of water)	Static Pressure Measurements with manometer (inches of water) ¹			Absolute pressures measured with pressure transducers (psi)		Time loading	Time to stop loading	Air flow (from venturi meter) (cfm)
			in bag	after bag	ΔP bag	between bag & filters (55481)	after final filters (53748)			
B	5	11.5	-1.1	-2.2	1.1	13.95	13.631	9:12am	9:14am	88.92
A		3.5	-0.5	-40	39.5	12.695	12.545			49.19
B	5	8.6	-0.9	-18.8	17.9	13.436	13.147	9:26am	9:28am	77.11
A		2.3	-0.7	-46.6	45.9	12.476	12.361			39.73
B	5	3.9	-0.4	-38.2	37.8	12.796	12.603	9:37am	9:39am	51.96
A		1.9	-0.3	-49.5	49.2	12.392	12.244			36.04
B	5	5.4	-0.6	-29.8	29.2	13.049	12.821	9:49am	9:50am	61.20
A		2.6	-0.3	-45	44.7	12.535	12.403			42.30
B	5	3.1	-0.3	-42.3	42	12.628	12.461	9:58am	9:59am	46.25
A		1.9	-0.2	-48.9	48.7	12.409	12.269			36.04
B	5	2.3	-0.4	-47.1	46.7	12.493	12.328	10:10am	10:12am	39.73
A		1.3	-0.2	-53.8	53.6	12.224	12.136			29.67
B	5	1.9	-0.2	-49.9	49.7	12.359	12.253	10:26am	10:28am	36.04
A		1.1	-0.1	-56.4	56.3	12.157	12.077			27.24
Final		1.5	-0.2	-52.9	52.7	12.283	12.169	10:35am		31.93

¹ Static pressure is the difference in pressure from atmospheric pressure. Negative static pressure indicates that pressure is less than atmospheric pressure.

Table C4. Pressure loss and air flows through Bosch vacuum Cleaner 9/14/2007 Round 2

Before (B) or after (A) adding 5 pounds	Total weight of debris transferred (lb)	Venturi meter ΔP (inches of water)	Static Pressure Measurements with manometer (inches of water) ¹			Absolute pressures measured with pressure transducers (psi)		Time loading	Time to stop loading	Air flow (from venturi meter) (cfm)
			in bag	after bag	ΔP bag	between bag & filters (55481)	after final filters (53748)			
B	5	10.8	-1.4	-4.3	2.9	13.874	13.539	11:40am	11:41am	86.24
A		5.2	-0.6	-31.4	30.8	13.015	12.787			60.05
B	5	6.6	-1.5	-25.8	24.3	13.201	12.963	11:49am	11:49am	67.64
A		3.3	-0.4	-31.2	30.8	12.67	12.495			47.75
B	5	6.5	-0.8	-26.8	26	13.175	12.904	11:56am	11:57am	67.13
A		2.5	-0.3	-45.9	45.6	12.527	12.344			41.46
B	5	3.6	-0.5	-40.5	40	12.704	12.545	12:03am	12:04am	49.90
A		2	-0.2	-48.7	48.5	12.426	12.278			37.00
B	5	2.9	-0.4	-42.9	42.5	12.628	12.461	12:10am	12:11am	44.71
A		1.6	-0.2	-51.5	51.3	12.325	12.194			33.00
B	5	2.2	-0.3	-47.5	47.2	12.476	12.328	12:18am	12:20am	38.84
A		1.2	-0.1	-54	53.9	12.241	12.127			28.48
B	5.4	4.7	-0.5	-33.5	33	13.268	12.746	12:27am	12:28am	57.08
A		1.6	-0.2	-51.3	51.1	12.325	12.211			33.00
Final		3.1	-0.4	-41.4	41	12.687	12.503	12:34am		46.25

¹ Static pressure is the difference in pressure from atmospheric pressure. Negative static pressure indicates that pressure is less than atmospheric pressure.

Table C5. Pressure loss and air flows through Bosch vacuum Cleaner 9/14/2007 Round 2

Before (B) or after (A) adding 5 pounds	Total weight of debris transferred (lb)	Venturi meter ΔP (inches of water)	Static Pressure Measurements with manometer (inches of water) ¹			Absolute pressures measured with pressure transducers (psi)		Time loading	Time to stop loading	Air flow (from venturi meter) (cfm)
			in bag	after bag	ΔP bag	between bag & filters (55481)	after final filters (53748)			
B	5	10.8	-1.4	-4.3	2.9	13.874	13.539	11:40am	11:41am	86.24
A		5.2	-0.6	-31.4	30.8	13.015	12.787			60.05
B	5	6.6	-1.5	-25.8	24.3	13.201	12.963	11:49am	11:49am	67.64
A		3.3	-0.4	-31.2	30.8	12.67	12.495			47.75
B	5	6.5	-0.8	-26.8	26	13.175	12.904	11:56am	11:57am	67.13
A		2.5	-0.3	-45.9	45.6	12.527	12.344			41.46
B	5	3.6	-0.5	-40.5	40	12.704	12.545	12:03am	12:04am	49.90
A		2	-0.2	-48.7	48.5	12.426	12.278			37.00
B	5	2.9	-0.4	-42.9	42.5	12.628	12.461	12:10am	12:11am	44.71
A		1.6	-0.2	-51.5	51.3	12.325	12.194			33.00
B	5	2.2	-0.3	-47.5	47.2	12.476	12.328	12:18am	12:20am	38.84
A		1.2	-0.1	-54	53.9	12.241	12.127			28.48
B	5.4	4.7	-0.5	-33.5	33	13.268	12.746	12:27am	12:28am	57.08
A		1.6	-0.2	-51.3	51.1	12.325	12.211			33.00
Final		3.1	-0.4	-41.4	41	12.687	12.503	12:34am		46.25

¹ Static pressure is the difference in pressure from atmospheric pressure. Negative static pressure indicates that pressure is less than atmospheric pressure.

APPENDIX D. Data for Dust Director Vacuum Cleaner Fan Curve (serial number PO7F14792)



Figure D-1. Locations for measuring static pressures inside the Dust Director vacuum cleaner. After sucking 5 pounds of debris into the vacuum cleaner, the vacuum cleaner hose was removed and manometer hose was inserted into the bag. Also, holes were drilled in the body of the vacuum cleaner tank and hoses were inserted into the spaces between the filters. And after the final filter.

Table D1. Fan curve air flow through Dust Director vacuum Cleaner 08/30/2007					
Static pressure (difference from atmospheric pressure) in inches of water	Pressure in psia	Pressure transducer data 55481 (psia)	Pressure transducer data 53748 (psia)	Venturimeter Pressure difference (inches of water)	vacuum cleaner air flow (cfm)
86.5	11.30	11.104	11.141	0	0.00
79.9	11.54	11.323	11.392	0.22	11.95
72.5	11.81	11.609	11.626	0.79	22.98
67.3	12.00	11.794	11.826	1.55	32.47
61.2	12.22	12.013	12.044	2.5	41.46
55.7	12.42	12.224	12.253	3.4	48.47
49.3	12.65	12.451	12.478	4.5	55.85
44.7	12.82	12.637	12.611	5.35	60.92
39.6	13.00	12.805	12.829	6.5	67.13
35	13.17	12.973	12.996	7.4	71.60
30.7	13.33	13.133	13.147	8.3	75.78
29.3	13.38	13.175	13.197	8.7	77.55
0	14.44	14.245	14.258	0	0.00
Barometric pressure 746.6 mm of Hg					
Temperature 24.5 C					

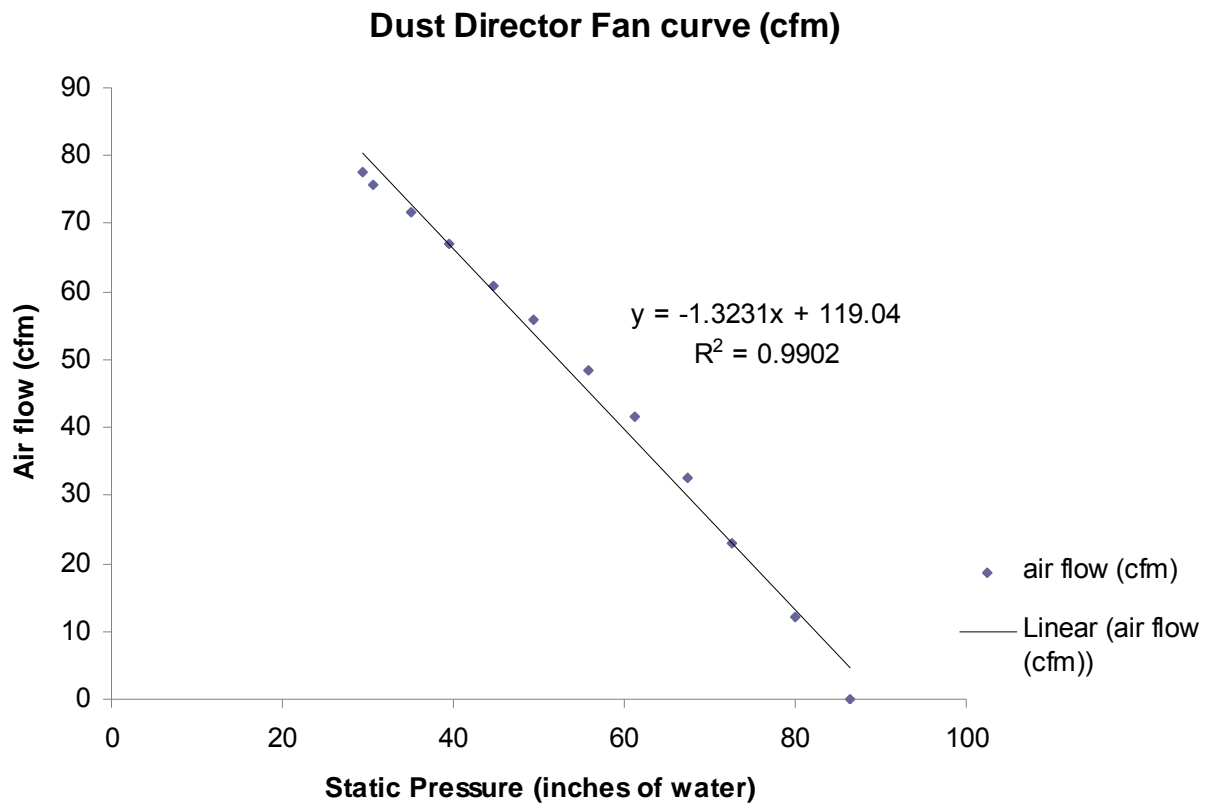

Figure D-2. Fan curve for Dust Director vacuum cleaner.

Table D2. Filter weights and environmental conditions.

	Barometric Pressure (mm of Hg)	Temperature (Celsius degrees)	Weight of filter 1 (green) before adding 35 lb of debris (grams)	Weight of filter 1 (green) after adding 35 lb of debris (grams)	Weight of filter 2 before adding 35 lb of debris (grams)	Weight of filter 2 after adding 35 lb of debris (grams)	Final weight of the vacuum cleaner bag (lb)
Round 1 10/04/2007	741.5	24.7	281	291	385	386	36.2
Round 2 10/04/2007	741.5	24.7	291	297	386	386	35.8
Round 3 10/11/2007	743.9	22.0	297	308	392	394	35.8

Table D3. Pressure loss and air flows through Dust Director vacuum cleaner 10-04-2007 Round 1

Before (B) or after (A) adding 5 pounds	Total weight of debris transferred (lb)	Venturi meter ΔP (inches of water)	Static Pressure Measurements with manometer (inches of water) ¹				Absolute pressures measured with pressure transducers (psi)			Time to start loading	Time to stop loading	Air flow (cfm)
			Pressure in vacuum cleaner bag (inches of water)	Pressure after the bag (inches of water)	Pressure after first filter (inches of water)	Pressure after second filter (inches of water)	Pressure after the bag (psi) 87614	Pressure after first filter (psi) 53748	Pressure after second filter (psi) 55481			
B	5.2	7.9	-3.7	-7.2	-8.4	-12	14.152	13.865	13.723	1:47pm	1:50pm	73.95
A		6	-2.6	-6.5	-35.7	-38.9	14.043	12.979	12.881			64.51
B	10.4	5.5	-3.5	-5.6	-34.7	-38	14.202	12.891	12.754	2:08pm	2:09pm	61.76
A		3.5	-1.3	-6.8	-50.6	-53.3	14.177	12.328	12.224			49.19
B	15.4	3.4	-1.5	-6.1	-50	-52.6	14.177	12.344	12.232	2:22pm	2:23pm	48.47
A		2.5	-1.5	-8.5	-57.8	-59.9	14.11	12.069	11.938			41.46
B	20.4	2.8	-1.6	-8.8	-55.6	-58.1	14.11	12.144	12.022	2:34pm	2:35pm	43.92
A		1.2	-1	-14.1	-63.9	-65.9	13.993	11.843	11.752			28.48
B	25.8	2	-1.1	-12.4	-62.5	-64.5	14.002	11.885	11.786	2:44pm	2:45pm	37.00
A		1.4	-0.85	-16.9	-66.5	-68.4	13.968	11.743	11.651			30.82
B	30.8	1.95	-1.1	-12.8	-62.2	-63.9	14.01	11.902	11.803	2:56pm	2:57pm	36.52
A		1.2	-0.9	-18.2	-68.4	-70	13.876	11.684	11.584			28.48
B	36	3.6	-2.2	-12	-49.8	-52.5	14.085	12.361	12.409	3:09pm	3:10pm	49.90
A		1.8	-1.2	-19.3	-63.9	-65.9	13.885	11.843	11.736			35.06
Final	36	3.5	-2	-13.5	-51.3	-54.2	13.977	12.303	12.157	3:18pm		49.19

¹ Static pressure is the difference in pressure from atmospheric pressure. These static pressures are less than atmospheric pressure

Table D4. Pressure loss and air flows through Dust Director vacuum cleaner 10-04-2007 Round 2

Before (B) or after (A) adding 5 pounds	Total weight of debris transferred (lb)	Venturi meter ΔP (inches of water)	Static Pressure Measurements with manometer (inches of water) ¹				Absolute pressures measured with pressure transducers (psi)			Time to start loading	Time to stop loading	Air flow (cfm)
			Pressure in vacuum cleaner bag (inches of water)	Pressure after the bag (inches of water)	Pressure after first filter (inches of water)	Pressure after second filter (inches of water)	Pressure after the bag (psi) 87614	Pressure after first filter (psi) 53748	Pressure after second filter (psi) 55481			
B	5.4	7.5	-6.3	-7.1	-14.4	-18.8	14.127	13.623	13.453	3:47pm	3:48pm	72.07
A		6.2	-4.4	-17.8	-28.2	-32.4	13.776	13.197	12.973			65.57
B	10.2	6	-4.2	-17.9	-30	-33.4	13.81	13.063	12.906	3:56pm	3:58pm	64.51
A		4.4	-2.2	-30.8	-43.9	-47.1	13.551	12.578	12.434			55.22
B	15.2	4.5	-2.2	-25.9	-42.7	-45.7	13.634	12.595	12.46	4:06pm	4:07pm	55.85
A		3.3	-1.9	-36.2	-52.2	-54.8	13.467	12.244	12.123			47.75
B	20.2	4.1	-2.5	-28.9	-46.5	-49.3	13.576	12.461	12.333	4:15pm	4:16pm	53.29
A		2.15	-2	-41.9	-57.6	-59.8	13.242	12.06	11.963			38.39
B	25	4.55	-3	-25.9	-42.5	-45.6	13.609	12.595	12.451	4:23pm	4:24pm	56.16
A		2.5	-1.35	-44.9	-59.1	-61.2	13.083	12.002	11.921			41.46
B	30	3.7	-2.2	-33.3	-49.2	-51.9	13.392	12.344	12.224	4:34pm	4:35pm	50.59
A		2.4	-1.4	-45.8	-59.4	-61.7	13.233	12.002	11.887			40.61
B	35.4	3.2	-1.65	-38.8	-54.8	-57	13.359	12.169	12.039	4:44pm	4:45pm	47.01
A		1.35	-0.9	-51.6	-63.9	-65.4	13.551	11.826	11.727			30.25
Final	35.4	3.4	-1.65	-38.5	-54	-56.9	13.484	12.177	12.039	4:50pm		48.47

¹ Static pressure is the difference in pressure from atmospheric pressure. These static pressures are less than atmospheric pressure.

Table D5. Pressure loss and air flows through Dust Director vacuum cleaner 10-11-2007 Round 3

Before (B) or after (A) adding 5 pounds	Total weight of debris transferred (lb)	Venturi meter ΔP (inches of water)	Static Pressure Measurements with manometer (inches of water) ¹				Absolute pressures measured with pressure transducers (psi)			Time to start loading	Time to stop loading	Air flow (cfm)
			Pressure in vacuum cleaner bag (inches of water)	Pressure after the bag (inches of water)	Pressure after first filter (inches of water)	Pressure after second filter (inches of water)	Pressure after the bag (psi) 87614	Pressure after first filter (psi) 53748	Pressure after second filter (psi) 55481			
B	5.4	8	-6.5	-7.2	-11.6	-15.5	14.202	13.765	13.588	4:50pm	4:51pm	74.41
A		6.4	-4.5	-11.5	-28.5	-31.8	14.093	13.172	12.998			66.62
B	10.6	6.3	-4.4	-11.5	-28.4	-32.2	14.085	13.155	12.864	4:59pm	5:00pm	66.10
A		5.1	-2.9	-16.9	-40.9	-44.2	13.943	12.729	12.544			59.47
B	15.6	4.5	-2.7	-7.8	-43.2	-46.6	14.21	12.612	12.493	5:08pm	5:09pm	55.85
A		3.3	-1.7	-8.9	-53.8	-56.7	14.194	12.269	12.098			47.75
B	20.8	5.4	-3.5	-6.7	-36.8	-40.5	14.21	12.854	12.695	5:17pm	5:18pm	61.20
A		3.3	-1.6	-7.6	-54.3	-57	14.235	12.244	12.089			47.75
B	25.8	4.3	-2.5	-6.2	-45.8	-49.4	14.252	12.512	12.359	5:26pm	5:27pm	54.58
A		2.5	-1.4	-6.9	-59.9	-62.7	14.244	12.027	11.887			41.46
B	30.8	5	-3	-6.5	-39.7	-43.7	14.227	12.746	12.586	5:38pm	5:39pm	58.88
A		2.8	-1.4	-8.8	-57.9	-60.6	14.16	12.119	11.954			43.92
B	36	4.4	-2.5	-7.3	-45.3	-48.8	14.185	12.545	12.392	5:46pm	5:47pm	55.22
A		2.2	-1.1	-12.6	-62.7	-65.4	14.06	11.927	11.803			38.84
Final	36	4.6	-2.5	-8.9	-43.8	-47.7	14.144	12.587	12.434	5:54pm		56.47

¹ Static pressure is the difference in pressure from atmospheric pressure. These static pressures are less than atmospheric pressure.

APPENDIX E. Comparison of absolute pressures and pressures obtained from pressure transducers.

During this study, pressure transducers were used to record vacuum cleaner static pressures and compute pressure differentials across filters. During efforts to develop the fan curves for the Bosch, DustDirector and Dust Control vacuum cleaners, simultaneous vacuum static pressures were recorded with the two pressure transducers and with the u-tube manometer. The pressure transducers measure an absolute pressure ($P_{transducer}$) in terms of pounds per square inch absolute (psia). In addition atmospheric pressure P_{atm} was recorded with a mercury barometer in units of mm of hg. The u-tube manometer P_{utube} and barometric pressures P_{atm} were used to compute an estimated absolute pressure P_{abs} in terms of pressure as follows:

$$P_{abs} = P_{atm} \frac{14.7 \text{ psia}}{760 \text{ mm of Hg}} - P_{utube} \frac{14.7 \text{ psia}}{407 \text{ inches of water}}$$

Regression analysis was used to fit the data to the following model:

$$P_{abs} = \text{intercept} + \text{slope} \times P_{transducer}$$

The data used to perform this regression analysis is listed in Table E1. The results of the regression analysis are listed in Table E2 and the regression results are stated after converting the regression terms which have pressure units of psia to inches of water. The R^2 for both pressure transducers was 0.9997. The standard error of estimate was 0.36 inches of water. This term is the standard deviation about the regression. Given that pressure losses through the filters was in excess of 10 inches of water and approached 60 inches of water, the errors in measuring filter pressure differences and vacuum cleaner static pressures seem reasonable. Clearly, the u-tube manometer measures static pressures in the vacuum cleaner with minimal error. However, a large u-tube manometer that is 11 feet high is not a device that would be practical for measuring and recording static pressures in vacuum cleaners at a construction site.

Table E1. Comparison of pressures.			
U-tube manometer pressure differential (inches of water)	barometric pressure (mm of Hg)	55481 (psia)	53748 (psia)
70.8	747.5	11.685	11.701
64.2		11.921	11.943
57.8		12.157	12.161
53.9		12.291	12.328
49.4		12.476	12.478
44.8		12.62	12.654
41.5		12.746	12.771
37.5		12.881	12.904
32.7		13.066	13.088
30.1		13.15	13.172
26.7		13.285	13.297
24.6		13.361	13.38
22.4		13.445	13.447
16.9		13.638	13.665
8.2		13.967	13.99
86.5		746.6	11.104
79.9	11.323		11.392
72.5	11.609		11.626
67.3	11.794		11.826
61.2	12.013		12.044
55.7	12.224		12.253
49.3	12.451		12.478
44.7	12.637		12.611
39.6	12.805		12.829
35	12.973		12.996
30.7	13.133		13.147
29.3	13.175		13.197
0	14.245	14.258	
0	14.287	14.316	
69.1	747.5	11.752	11.793
61.4		12.03	12.06
54.3		12.3	12.328
46.2		12.586	12.629
41.5		12.771	12.796
36.3		12.965	12.979
31		13.133	13.172
27.2		13.285	13.305
24.2		13.403	13.431
20.7		13.52	13.548
17.3		13.638	13.665
14.9		13.731	13.739
13	13.798	13.823	
8	13.984	13.999	
6	14.051	14.066	

Table E2. Regression analyses for predicting actual pressures from pressure transducer response.		
Regression statistics	Pressure transducer number	
	serial number 53478	serial number 55481
Intercept (inches of water)	4.883613	4.907729
Slope (dimensionless)	0.999582	0.999582
Std error of estimate (inches of water)	0.367395	0.367395
Std error, intercept (inches of water)	0.902162	0.902162
Std error, slope (dimension less)	0.002526	0.002526
N	44	44
R ²	0.9997254	0.9997254